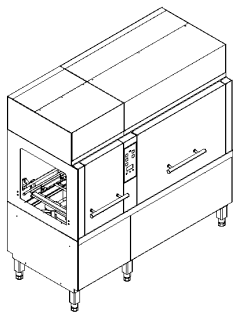
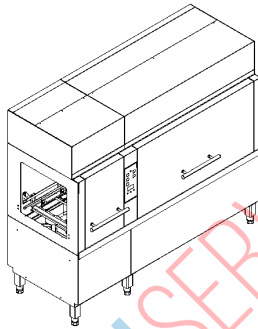
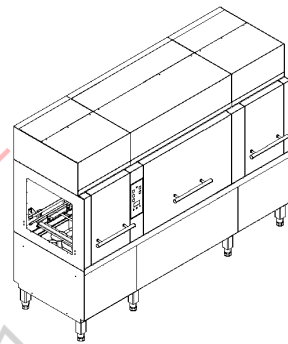
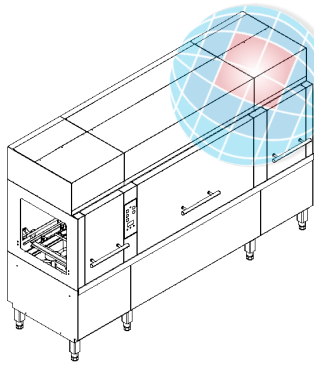
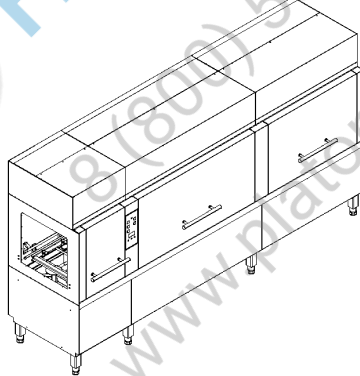
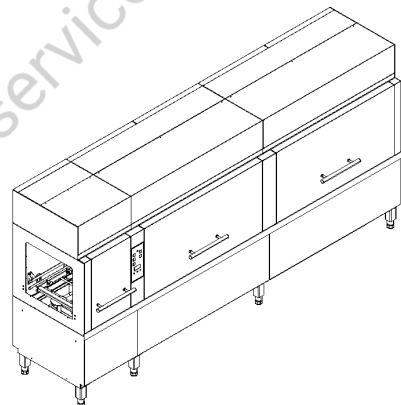

## Lavastoviglie a cesto trascinato modulari Modular Rack Type dishwasher

**RTM140/WTM140****RTM165/WTM165****RTM180/WTM180****RTM200/WTM200****WTM250****WTM300**

Marchio/Brand: **E**  
Paese/Country: **Tutti/All**

Da Ser.Nr./From Ser.nr.: 544

Page: 1 Ed. 2016-10

Doc. Nr.: **6-52 001**

## INDICE / INDEX

Disegno/ Drawing	Descrizione / Description	Pagina/ Page
ill. 652001p1B	Risciacquo da 600, vista generale / Rinse from 600, Main view	4
	Lista ricambi / Spare parts list	5
ill. 652001p2A	Lavaggio da 1165, vista generale / Wash from 1165, Main view	8
	Lista ricambi / Spare parts list	9
ill. 652001p3A	Lavaggio da 1490, vista generale / Wash from 1490, Main view	11
	Lista ricambi / Spare parts list	12
ill. 652001p4A	Prelavaggio da 600, vista generale / Prewash from 600, Main view	14
	Lista ricambi / Spare parts list	15
ill. 652001p5A	Prelavaggio da 1165, vista generale / Prewash from 1165, Main view	17
	Lista ricambi / Spare parts list	18
ill. 652001p6A	Prelavaggio da 1490, vista generale / Prewash from 1490, Main view	20
	Lista ricambi / Spare parts list	21
ill. 652001p7	Risciacquo da 600, Circuito Idraulico / Rinse from 600, Hydraulic circuit	23
	Lista ricambi / Spare parts list	24
ill. 652001p8A	Lavaggio da 1165, Circuito Idraulico / Wash from 1165, Hydraulic circuit	27
	Lista ricambi / Spare parts list	28
ill. 652001p9	Lavaggio da 1490, Circuito Idraulico / Wash from 1490, Hydraulic circuit	31
	Lista ricambi / Spare parts list	32
ill. 652001p10A	Prelavaggio da 600, Circuito Idraulico / Prewash from 600, Hydraulic circuit	35
	Lista ricambi / Spare parts list	36
ill. 652001p11A	Prelavaggio da 1165, Circuito Idraulico / Prewash from 1165, Hydraulic circuit	38
	Lista ricambi / Spare parts list	39
ill. 652001p12	Prelavaggio da 1490, Circuito Idraulico / Prewash from 1490, Hydraulic circuit	41
	Lista ricambi / Spare parts list	42
ill. 652001p13	Risciacquo da 600, Componenti elettrici / Rinse from 600, Electrical components	45
	Lista ricambi / Spare parts list	46
ill. 652001p14A	Lavaggio da 1165, Componenti elettrici / Wash from 1165, Electrical components	49
	Lista ricambi / Spare parts list	50
ill. 652001p15A	Lavaggio da 1490, Componenti elettrici / Wash from 1490, Electrical components	52
	Lista ricambi / Spare parts list	53
ill. 652001p16A	Prelavaggio da 600, Componenti elettrici / Prewash from 600, Electrical components	55
	Lista ricambi / Spare parts list	57
ill. 652001p17A	Prelavaggio da 1165, Componenti elettrici / Prewash from 1165, Electrical components	58
	Lista ricambi / Spare parts list	60
ill. 652001p18A	Prelavaggio da 1490, Componenti elettrici / Prewash from 1490, Electrical components	61
	Lista ricambi / Spare parts list	63

Da Ser.Nr./From Ser.nr.: 544

Page: 2 Ed. 2011-12

Doc. Nr.: **6-52 001**

## PROSPETTO COMPOSIZIONE MODULI / VIEW OF MODULE COMPOSITION

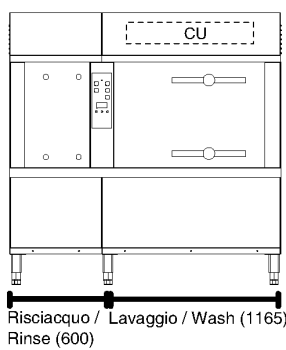
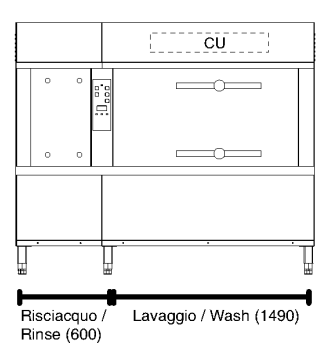
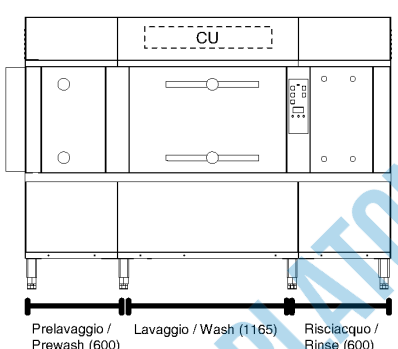
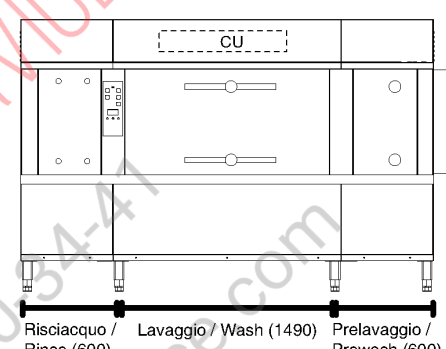
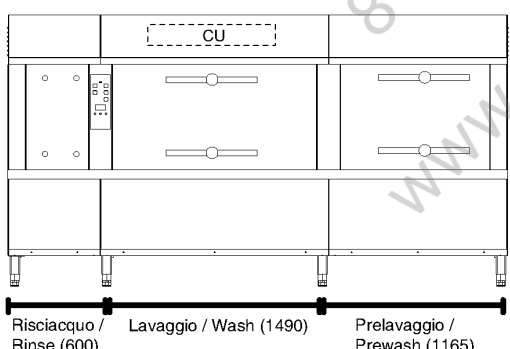
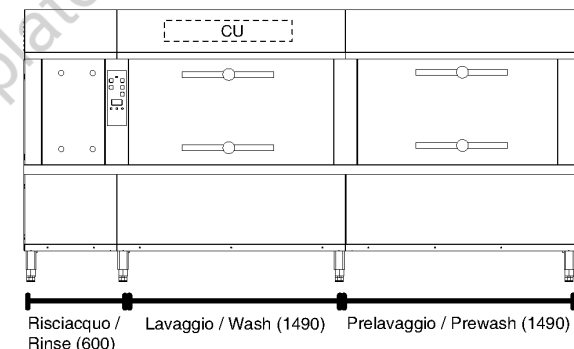
RTM140/WTM140	RTM165/WTM165
 <p style="text-align: center;">Risciacquo / Rinse (600)    Lavaggio / Wash (1165)</p>	 <p style="text-align: center;">Risciacquo / Rinse (600)    Lavaggio / Wash (1490)</p>
ill. 652001p1B pag. 4    ill. 652001p2A pag. 8 ill. 652001p7 pag. 23    ill. 652001p8A pag. 27 ill. 652001p13 pag. 45    ill. 652001p14A pag. 49	ill. 652001p1B pag. 4    ill. 652001p3A pag. 11 ill. 652001p7 pag. 23    ill. 652001p9 pag. 31 ill. 652001p13 pag. 45    ill. 652001p15A pag. 52
RTM180/WTM180	RTM200/WTM200
 <p style="text-align: center;">Prelavaggio / Prewash (600)    Lavaggio / Wash (1165)    Risciacquo / Rinse (600)</p>	 <p style="text-align: center;">Risciacquo / Rinse (600)    Lavaggio / Wash (1490)    Prelavaggio / Prewash (600)</p>
ill. 652001p1B pg.4    ill. 652001p2A pg. 8    ill. 652001p4A pg.14 ill. 652001p7pg23    ill. 652001p8A pg27    ill. 652001p10A pg35 ill. 652001p13pg 45    ill. 652001p14Apg 49    ill. 652001p16Apg55	ill. 652001p1B pg.4    ill. 652001p3A pag. 11    ill. 652001p4A pg.14 ill. 652001p7pg23    ill. 652001p9 pag. 31    ill. 652001p10A pg35 ill. 652001p13pg 45    ill. 652001p15A pag. 52    ill. 652001p16Apg55
WTM250	WTM300
 <p style="text-align: center;">Risciacquo / Rinse (600)    Lavaggio / Wash (1490)    Prelavaggio / Prewash (1165)</p>	 <p style="text-align: center;">Risciacquo / Rinse (600)    Lavaggio / Wash (1490)    Prelavaggio / Prewash (1490)</p>
ill. 652001p1B pg 4    ill. 652001p3A pg.11    ill. 652001p5A pg. 17 ill. 652001p7 pg. 23    ill. 652001p9 pg. 31    ill. 652001p11A pg. 38 ill. 652001p13 pg45    ill. 652001p15A pg52    ill. 652001p17A pg58	ill. 652001p1B pg 4    ill. 652001p3A pg.11    ill. 652001p5A pg. 17 ill. 652001p7 pg. 23    ill. 652001p9 pg. 31    ill. 652001p11A pg. 38 ill. 652001p13 pg45    ill. 652001p15A pg52    ill. 652001p17A pg58

Da Ser.Nr./From Ser.nr.: 544

Page: 3 Ed. 2008-09

Doc. Nr.: 6-52 001

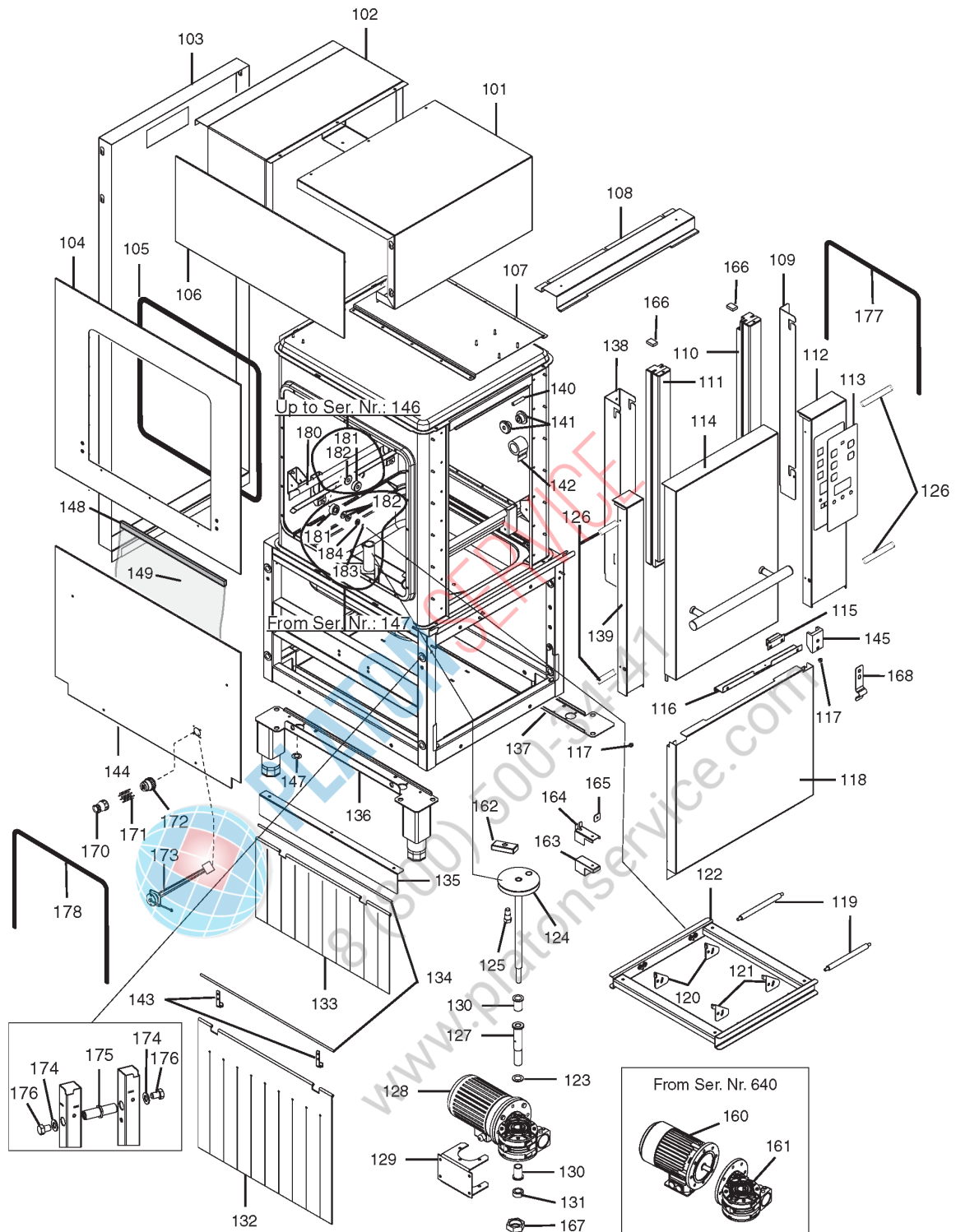

**ill. 652001p1B**  
**Risciacquo da 600, vista generale / Rinse from 600, Main view**

Da Ser.Nr./From Ser.nr.: 544

Page: 4 Ed. 2013-03

**Doc. Nr.: 6-52 001**

??????	534121									
??????	6-52001		???????? 4				Rinse from 600, Main view			
.		Alias		S			.			(Euro)
0101	0L0823	830652101						COVERING		137.00
0102	0L0824	830651600						COVERING; FIX		114.70
0103	0L0825	830652800						BACK PANEL; M600 NEWRT		191.80
0104	0L0826	830638203						LEFT PANEL		187.80
0105	0L0827	543630300						GASKET		26.59
0106	0L0828	805662501						SIDE; ASSY INT.	Up to Ser. Nr. 724	233.50
0106	0L1584	830651401						SIDE PANEL; ASSY	From Ser. Nr. 725	76.94
0107	000000	830655Y00							From Ser. Nr. 4511	
0107	0L0829	830640500						SUPPORT; AIR GAP	Up to Ser. Nr. 706	73.59
0107	0L1442	830640502						SUPPORT; ASSY; NEWRT	From Ser. Nr. 713	61.51
0107	0L1442	830640502						SUPPORT; ASSY; NEWRT	Up to Ser. Nr. 4501	61.51
0108	0L0830	503604200	0L1176					CRANKCASE	Up to Ser. Nr. 616	
0108	0L1176	503604203						PROTECTION; M600	From Ser. Nr. 617	51.77
0109	0L0831	502697802						SUPPORT; DX PANEL	Up to Ser. Nr. 724	41.31
0109	0L1047	830643101						SUPPORT; ASSY; DX NEWRT	From Ser. Nr. 811	34.92
0109	0L1472	502697803						SUPPORT; DX NEWRT	From Ser. Nr. 725 - Up to Ser. Nr. 810	38.67
0110	0L0832	830637101		S				DOOR GUIDE; RH		91.65
0111	0L0833	830637201		S				DOOR GUIDE; LH		91.65
0112	0L0834	830639503						PANEL; USER INTERFACE	Up to Ser. Nr. 810	186.00
0112	0L1752	830654J01						PANEL; ASSY	From Ser. Nr. 811	104.50
0113	0L0836	548642101						ADHESIVE MEMBRANE; LH	Up to Ser. Nr. 810	94.40
0113	0L0878	548643100						ADHESIVE MEMBRANE; DX ELUX NRT 218J	Up to Ser. Nr. 810	94.40
0113	0L1740	548648N00						ADHESIVE MEMBRANE; RIGHT	Electrolux - From Ser. Nr. 811	56.33
0113	0L1741	548648O00						ADHESIVE MEMBRANE; LEFT	Electrolux - From Ser. Nr. 811	56.33
0113	0L1742	548648P00						ADHESIVE MEMBRANE; RIGHT	Zanussi - From Ser. Nr. 811	72.47
0113	0L1743	548648Q00						ADHESIVE MEMBRANE; LEFT	Zanussi - From Ser. Nr. 811	72.47
0114	0L0837	835620302						DOOR ASSEMBLY		482.10
0115	0E2898	W00143601		S				SPRING RETAINER		14.89
0116	0L1168	504696703						SPLASH GUARD; M600 NEWRT		15.62
0117	0L0839	549644800						PEG		2.84
0118	0L0840	503601302						PANEL; LOWER		128.90
0119	0L0841	514695200						SHAFT		18.68
0120	0L0842	504696100	0L1314		D			TOOTH; DX	Up to Ser. Nr. 638	
0120	0L1314	5046A3800		S				TOOTH; DX	From Ser. Nr. 639	16.03
0121	0L0843	504696200	0L1315		D			TOOTH; SX	Up to Ser. Nr. 638	
0121	0L1315	5046A3900		S				TOOTH; SX	From Ser. Nr. 639	16.03

??????	534121									
??????	6-52001		???????? 4				Rinse from 600, Main view			
.		Alias		S			.			(Euro)
0122	0L0844	830632200	0L1306				SLIDE	Up to Ser. Nr. 638		
0122	0L1306	830632203					FEEDING LADDER; M600 RINSE NEWRT	From Ser. Nr. 639	183.70	
0123	0L0152	RT0020700		S			SPRING; MM.50X25,4X3,4H		4.50	
0124	0L1309	835620202					DRIVE AXIS; NEW RT		142.10	
0125	0L0846	514695101	0L1278				PIVOT; NEW RT	Up to Ser. Nr. 638		
0125	0L1278	514695102		S			PIVOT; FOR BUSHING NEWRT	From Ser. Nr. 639	20.60	
0126	0L2968	140600700					HOSE; BY METER; DIA. 8X6MM		2.11	
0127	0L0847	514695001		S			ROD; GEAR MOTOR		125.90	
0128	0L0848	611630700				Kit	GEARMOTOR; KIT	Up to Ser. Nr. 639	524.00	
0129	0L0849	830640401					SUPPORT; GEAR MOTOR	Up to Ser. Nr.: 928	91.86	
0129	0L2091	504696302					MOTOR BRACKET	From Ser. Nr.: 929 - Up to Ser. Nr.: 019	30.86	
0129	0L2317	504696303					MOTOR BRACKET	From Ser. Nr.: 020	29.54	
0130	0E5043	W00115100		S			FLANGED BUSH		9.29	
0131	0E5187	W00111300		S			RING		10.87	
0132	0L0850	541612302	0L3207	S			CURTAIN; DOUBLE; 580X490 MM	Up to Ser. Nr.: 928		
0132	0L1732	541617000		S			CURTAIN; DOUBLE; 580X490MM; PVC	From Ser. Nr.: 929	114.70	
0133	0L0851	541612402	0L3208	S			CURTAIN; SINGLE; SHORT; 580X305MM	Up to Ser. Nr.: 928		
0133	0L1733	541617100		S			CURTAIN; SINGLE; PVC	From Ser. Nr.: 929	67.09	
0134	0E5826	RT0003700		S			CURTAIN AXIS; L=580 MM		16.80	
0135	0L0852	800667800					SUPPORT; SINGLE SHORT CURTAIN		37.86	
0136	0L0853	503603601					FOOT WITH FRAME	Not for steam version	110.60	
0136	0L1514	503615701					FOOT; ASSY; NEWRT	For steam version	124.80	
0137	0L0854	502696002					SUPPORT; FEET SUPPORT NEWRT	Not for steam version	35.73	
0137	0L1552	5026A7000					FOOT; ASSY	For steam version	47.30	
0138	0L1169	830643200					SUPPORT; FOR PANEL NEWRT	Up to Ser. Nr.: 724	52.98	
0138	0L1169	830643202					SUPPORT; FOR PANEL NEWRT	From Ser. Nr.: 811	52.98	
0138	0L1473	502697703					SUPPORT; FRONT PANEL UPPER	From Ser. Nr.: 725 - Up to Ser. Nr.: 810	52.07	
0139	0L0856	830641103					PANEL; SLIM		68.31	
0140	0L0857	515659300		S			ROLL		6.12	
0141	0L0858	546631000		S			BUSHING; SPRING SUPPORT	Up to Ser. Nr.: 616	9.29	
0141	0L1170	546631100		S			BUSHING; FOR SPRING NEWRT	From Ser. Nr.: 617	7.18	
0142	0E5158	W00093200		S			SPRING; BLADE 25X0, 5 MM	Up to Ser. Nr.: 616	49.74	
0142	0E5167	W00093300		S			SPRING BLADE; 38X0,5 MM	From Ser. Nr.: 617	56.10	
0143	0L0997	RT0021201					SUPPORT; FOR CURTAIN	Up to Ser. Nr.: 616	12.36	
0143	0L1171	503610500		S			HOOK; NEWRT	From Ser. Nr.: 617	15.52	
0144	0L0860	502690806					LEFT SIDE		132.00	

?????? 534121  
 ?????? 6-52001 ????????? 4 Rinse from 600, Main view

		Alias		S					(Euro)
0145	0L0861	541612801		S				DOOR CATCH	2.43
0147	0L0993	541612500						PLUG; PLASTIC	1.02
0148	049931	590603500		S				VELCRO; BY MT.	From Ser. Nr.: 147 6.45
0149	0L2554	569608F00						FOIL PROTECTION	From Ser. Nr.: 147 8.16
0160	0L1280	611634100		S				MOTOR; 110/190V 50HZ	From Ser. Nr.: 640 268.00
0161	0L1281	835621300		S				GEARMOTOR	From Ser. Nr.: 640 337.00
0162	0L1275	547604600		S				GLIDE SHOE; NEWRT	28.42
0163	0L1471	543631300		S				GASKET; NEWRT	13.62
0164	0L1470	502697402						BRACKET; FOR GASKET NEWRT	12.25
0165	0L1469	503609200						PLAQUE; FOR GASKET NEWRT	3.69
0166	0L1597	565615200						DOOR GASKET; NEWRT	1.68
0167	0L0151	RT0020500	0L1712			CGX200 8-05		NUT	
0168	0L1528	507690700		S				SPRING LATCH	11.41
0170	0L1644	699604800						CAP	19.69
0171	0L1645	639628000						ELECTRIC SOCKET	19.53
0172	0L1646	699604900						END PIECE MALE; BAG 10 PCS	18.36
0173	0L1763	638687B00						CABLE; IN	119.80
0173	0L1764	638687C00						CABLE; OUT	133.00
0174	0L2329	206008195						WASHER; DIA.15X28	From Ser. Nr.: 020 1.02
0175	0L2324	5146A2401						SPACER	From Ser. Nr.: 020 20.00
0176	0L2328	217018205						SCREW; M14X20	From Ser. Nr.: 020 3.24
0177	0L2167	543633J00						GASKET	From Ser. Nr.: 020 30.45
0178	0L2311	543633H00		S				GASKET	From Ser. Nr.: 020 30.45
0180	0L1324	830631801	0L2594					BASKET GUIDE; ASSY M600 NEW RT	Up to Ser. Nr.: 146
0180	0L2594	835621Y00		S				BASKET GUIDE; ASSY; M600 RINSE NEWRT	From Ser. Nr.: 147 203.00
0181	0L2443	W00017300		S				ROLLER; Ø=40MM; H=16MM; WHITE	Up to Ser. Nr.: 146 5.81
0181	0L2520	547604800		S				ROLLER	From Ser. Nr.: 147 6.02
0182	0L2174	549646100		S				WASHER	From Ser. Nr.: 147 1.58
0183	0L2522	219614400		S				SNAP RING	From Ser. Nr.: 147 1.02
0184	0L2521	5066A0R00		S				DISC	From Ser. Nr.: 147 4.44

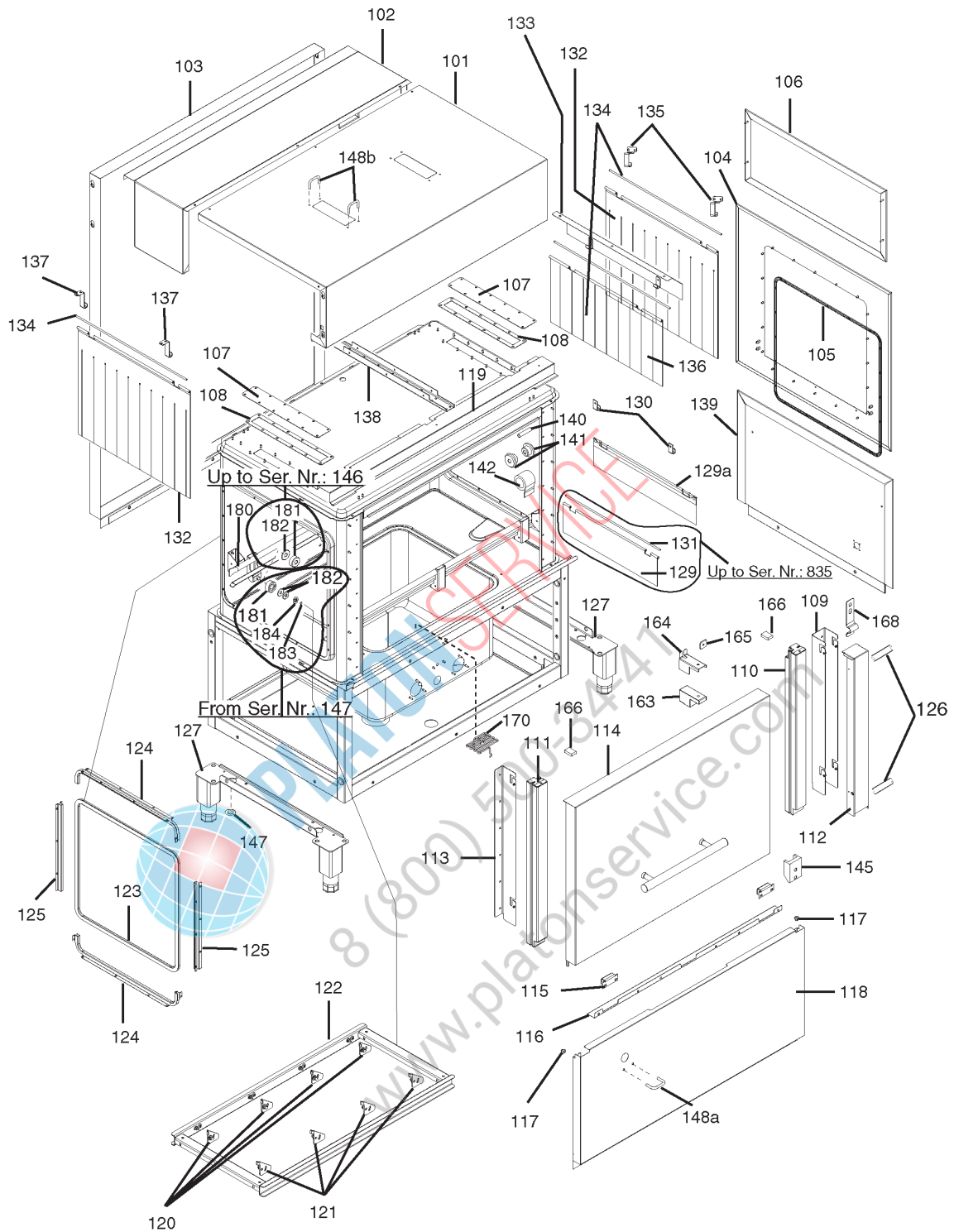

ill. 652001p2A

Lavaggio da 1165, vista generale / Wash from 1165, Main view

Da Ser.Nr./From Ser.nr.: 544

Page: 8 Ed. 2013-03

Doc. Nr.: 6-52 001



??????		534121									
??????		6-52001		???????? 8		Wash from 1165, Main view					
.		Alias		S			.			(Euro)	
0101	000000	83065GA00							From Ser. Nr.: 5151		
0101	0L0869	830652302						COVERING	Up to Ser. Nr.: 5141	234.50	
0102	0L0865	830651700						COVERING; FIX		155.30	
0103	0L0864	830653002						BACK PANEL		311.60	
0104	0L0880	830638303						PANEL; RH		187.80	
0105	0L0875	543629700						GASKET		19.43	
0106	0L0828	805662501						SIDE; ASSY INT.	Up to Ser. Nr.: 724	233.50	
0106	0L1584	830651401						SIDE PANEL; ASSY	From Ser. Nr.: 725	76.94	
0107	0L0877	800667301						PLUG; ASSY		35.02	
0108	0L0876	543631001						GASKET		12.57	
0109	0L1169	830643200						SUPPORT; FOR PANEL NEWRT	Up to Ser. Nr.: 724	52.98	
0109	0L1169	830643202						SUPPORT; FOR PANEL NEWRT	From Ser. Nr.: 811	52.98	
0109	0L1473	502697703						SUPPORT; FRONT PANEL UPPER	From Ser. Nr.: 725 - Up to Ser. Nr.: 810	52.07	
0110	0L0832	830637101		S				DOOR GUIDE; RH		91.65	
0111	0L0833	830637201		S				DOOR GUIDE; LH		91.65	
0112	0L0856	830641103						PANEL; SLIM		68.31	
0113	0L0862	502697901						SUPPORT; SX	Up to Ser. Nr.: 724	44.05	
0113	0L1049	830643001						SUPPORT; ASSY; SX NEWRT	From Ser. Nr.: 811	34.92	
0113	0L1474	502697902						SUPPORT; SX NEWRT	From Ser. Nr.: 725 - Up to Ser. Nr.: 810	108.60	
0114	0L0881	835620502						DOOR ASSEMBLY		650.00	
0115	0E2898	W00143601		S				SPRING RETAINER		14.89	
0116	0L0868	504696602						SPLASH GUARD		23.14	
0117	0L0839	549644800						PEG		2.84	
0118	0L1182	503601103						PANEL; LOWER M1165 NEWRT	Up to Ser. Nr.: 616	264.90	
0118	0L1266	503615601						PANEL; M1165 NEWRT	From Ser. Nr.: 617 - Up to Ser. Nr.: 146	225.30	
0118	0L2635	503615602						FRONT PANEL	From Ser. Nr.: 147	221.30	
0119	000000	50361CX00							From Ser. Nr. 5151		
0119	0L0866	503604401	0L1178					CRANKCASE	Up to Ser. Nr.: 616		
0119	0L1178	503610902						PROTECTION; M1165	From Ser. Nr.: 617	61.00	
0119	0L1178	503610902						PROTECTION; M1165	Up Ser. Nr. 5141	61.00	
0120	0L0842	504696100	0L1314		D			TOOTH; DX	Up to Ser. Nr.: 638		
0120	0L1314	5046A3800		S				TOOTH; DX	From Ser. Nr.: 639	16.03	
0121	0L0843	504696200	0L1315		D			TOOTH; SX	Up to Ser. Nr.: 638		
0121	0L1315	5046A3900		S				TOOTH; SX	From Ser. Nr.: 639	16.03	
0122	0L0879	830632400	0L1303					SLIDE	Up to Ser. Nr.: 638		
0122	0L1303	830632403						FEEDING LADDER; M1165 NEW RT	From Ser. Nr.: 639	263.90	

??????	534121									
??????	6-52001		???????? 8					Wash from 1165, Main view		
.		Alias		S			.			(Euro)
0123	0L0827	543630300						GASKET		26.59
0124	0L0992	502697601						COVERING; NEWRT		36.24
0125	0L0991	502697501						COVERING		25.78
0126	0L2968	140600700						HOSE; BY METER; DIA. 8X6MM		2.11
0127	0L0853	503603601						FOOT WITH FRAME	Not for steam version	110.60
0127	0L1514	503615701						FOOT; ASSY; NEWRT	For steam version	124.80
0129	0L0874	541613001			D		CGX200 8-18	CURTAIN; NEWRT	Up to Ser. Nr.: 835	54.81
0130	0L0955	805662800						HOOK; FOR CURTAIN		12.04
0131	0L0873	514699200		S				CURTAIN AXIS; L=490	Up to Ser. Nr.: 835	15.86
0132	0L0850	541612302	0L3207	S				CURTAIN; DOUBLE; 580X490 MM	Up to Ser. Nr.: 928	
0132	0L1732	541617000		S				CURTAIN; DOUBLE; 580X490MM; PVC	From Ser. Nr.: 929	114.70
0133	0L0852	800667800						SUPPORT; SINGLE SHORT CURTAIN		37.86
0134	0E5826	RT0003700		S				CURTAIN AXIS; L=580 MM		16.80
0135	0L0870	505600000						HOOK; CURTAIN	Up to Ser. Nr.: 616	20.91
0135	0L1172	505600001						HOOK; FOR CURTAIN NEWRT	From Ser. Nr.: 617	15.10
0136	0L0851	541612402	0L3208	S				CURTAIN; SINGLE; SHORT; 580X305MM	Up to Ser. Nr.: 928	
0136	0L1733	541617100		S				CURTAIN; SINGLE; PVC	From Ser. Nr.: 929	67.09
0137	0L0871	507687300						HOOK; CURTAIN		13.30
0138	0L0867	503607302						REINFORCEMENT		22.43
0139	0L0859	502696105						RIGHT SIDE; DX		132.00
0140	0L0857	515659300		S				ROLL		6.12
0141	0L0858	546631000		S				BUSHING; SPRING SUPPORT	Up to Ser. Nr.: 616	9.29
0141	0L1170	546631100		S				BUSHING; FOR SPRING NEWRT	From Ser. Nr.: 617	7.18
0142	0E5158	W00093200		S				SPRING; BLADE 25X0, 5 MM	Up to Ser. Nr.: 616	49.74
0142	0E5167	W00093300		S				SPRING BLADE; 38X0,5 MM	From Ser. Nr.: 617	56.10
0145	0L0861	541612801		S				DOOR CATCH		2.43
0147	0L0993	541612500						PLUG; PLASTIC		1.02
0163	0L1471	543631300		S				GASKET; NEWRT		13.62
0164	0L1470	502697402						BRACKET; FOR GASKET NEWRT		12.25
0165	0L1469	503609200						PLAQUE; FOR GASKET NEWRT		3.69
0166	0L1597	565615200						DOOR GASKET; NEWRT		1.68
0168	0L1528	507690700		S				SPRING LATCH		11.41
0170	0L2515	5146A4100		S				PROTECTIVE GRATING	From Ser. Nr.: 147	19.79
0180	0L1704	830632001	0L2593					BASKET GUIDE; ASSY; M1165 NEWRT	Up to Ser. Nr.: 146	
0180	0L2593	835621X00						BASKET GUIDE; ASSY; M1165 NEWRT	From Ser. Nr.: 147	234.50
0181	0L2443	W00017300		S				ROLLER; Ø=40MM; H=16MM; WHITE	Up to Ser. Nr.: 146	5.81

??????	534121									
??????	6-52001		???????? 8				Wash from 1165, Main view			
.		Alias		S			.			(Euro)
0181	0L2520	547604800		S			ROLLER		From Ser. Nr.: 147	6.02
0182	0L2174	549646100		S			WASHER		From Ser. Nr.: 147	1.58
0183	0L2522	219614400		S			SNAP RING		From Ser. Nr.: 147	1.02
0184	0L2521	5066A0R00		S			DISC		From Ser. Nr.: 147	4.44
148b	0L2514	5146A4F00					PROTECTION		From Ser. Nr.: 147 - Only for machine with CU	18.69



**PLATON SERVICE**

8 (800) 500-34-47

www.platonservice.com

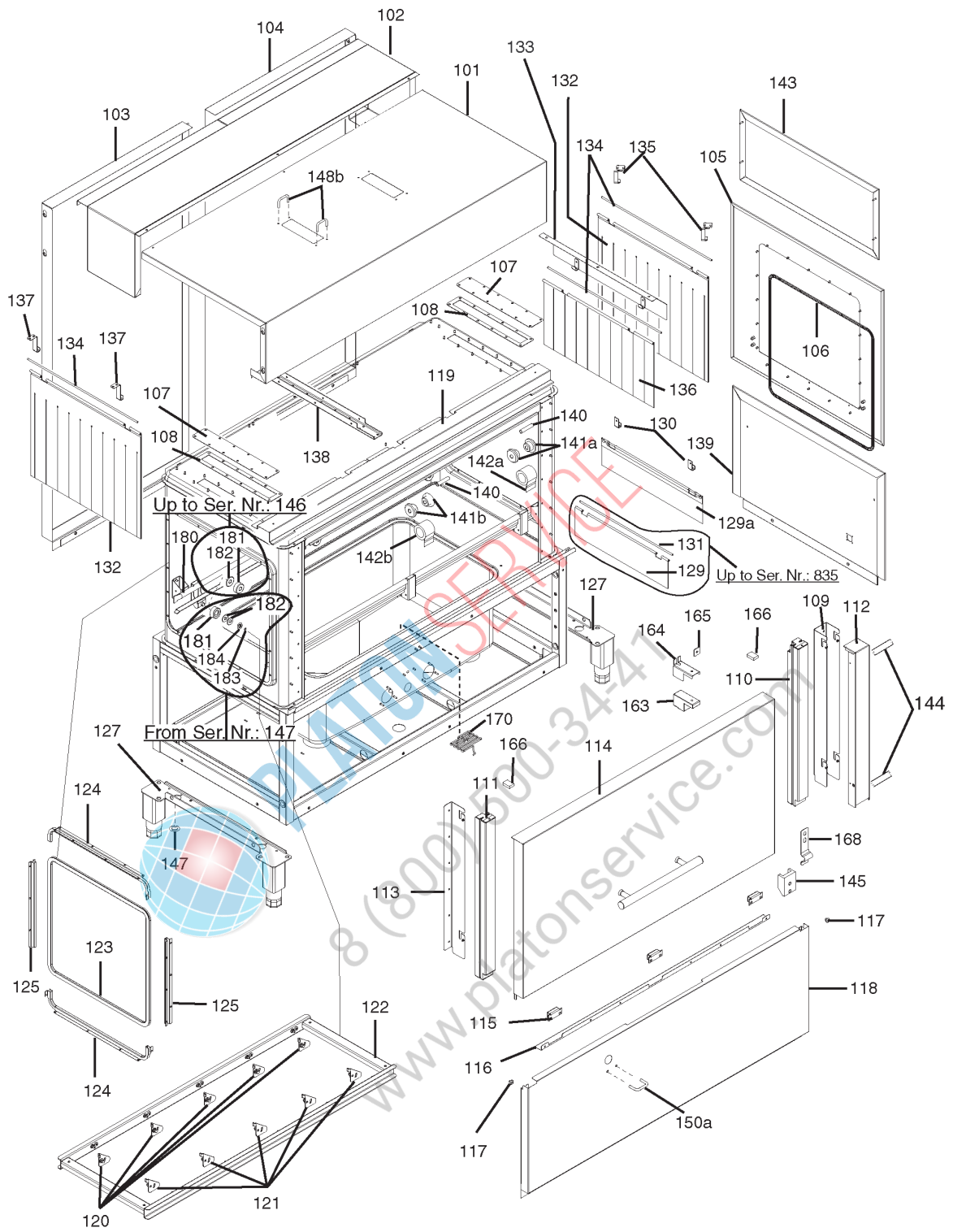

ill. 652001p3A

Lavaggio da 1490, vista generale / Wash from 1490, Main view

Da Ser.Nr./From Ser.nr.: 544

Page: 11 Ed. 2013-03

Doc. Nr.: 6-52 001

??????	534121									
??????	6-52001		???????? 11				Wash from 1490, Main view			
.		Alias		S			.			(Euro)
0101	0L0897	830652402					COVER PLATE			268.00
0102	0L0885	830651800					COVERING			169.50
0103	0L0889	830653202					BACK PANEL; SX			180.70
0104	0L0884	830653102					BACK PANEL			176.60
0105	0L0880	830638303					PANEL; RH			187.80
0106	0L0875	543629700					GASKET			19.43
0107	0L0877	800667301					PLUG; ASSY			35.02
0108	0L0876	543631001					GASKET			12.57
0109	0L1169	830643200					SUPPORT; FOR PANEL NEWRT	Up to Ser. Nr.: 724		52.98
0109	0L1169	830643202					SUPPORT; FOR PANEL NEWRT	From Ser. Nr.: 811		52.98
0109	0L1473	502697703					SUPPORT; FRONT PANEL UPPER	From Ser. Nr.: 725 - Up to Ser. Nr.: 810		52.07
0110	0L0832	830637101		S			DOOR GUIDE; RH			91.65
0111	0L0833	830637201		S			DOOR GUIDE; LH			91.65
0112	0L0856	830641103					PANEL; SLIM			68.31
0113	0L0862	502697901					SUPPORT; SX	Up to Ser. Nr.: 724		44.05
0113	0L1049	830643001					SUPPORT; ASSY; SX NEWRT	From Ser. Nr.: 811		34.92
0113	0L1474	502697902					SUPPORT; SX NEWRT	From Ser. Nr.: 725 - Up to Ser. Nr.: 810		108.60
0114	0L0989	835620601					DOOR ASSEMBLY			715.00
0115	0E2898	W00143601		S			SPRING RETAINER			14.89
0116	0L0896	504696502					SPLASH GUARD; 1211MM			41.62
0117	0L0839	549644800					PEG			2.84
0118	0L0883	503601001					PANEL; LOWER	Up to Ser. Nr.: 616		168.50
0118	0L1183	503601004					PANEL; LOWER M1490NEWRT	From Ser. Nr.: 617 - Up to Ser.Nr.: 146		238.50
0118	0L2634	503601005					FRONT PANEL	From Ser. Nr.: 147		231.40
0119	000000	50361CY00						From Ser. Nr.: 5151		
0119	0L0886	503604501	0L1177				CRANKCASE	Up to Ser. Nr.: 616		
0119	0L1177	503614102					PROTECTION; M1490; 1489MM	From Ser. Nr.: 617		61.51
0119	0L1177	503614102					PROTECTION; M1490; 1489MM	Up to Ser. Nr.: 5141		61.51
0120	0L0842	504696100	0L1314		D		TOOTH; DX	Up to Ser. Nr.: 638		
0120	0L1314	5046A3800		S			TOOTH; DX	From Ser. Nr.: 639		16.03
0121	0L0843	504696200	0L1315		D		TOOTH; SX	Up to Ser. Nr.: 638		
0121	0L1315	5046A3900		S			TOOTH; SX	From Ser. Nr.: 639		16.03
0122	0L0956	830632500	0L1304				SLIDE	Up to Ser. Nr.: 638		
0122	0L1304	830632503					FEEDING LADDER; M1490 NEW RT	From Ser. Nr.: 639		308.60
0123	0L0827	543630300					GASKET			26.59
0124	0L0992	502697601					COVERING; NEWRT			36.24

??????	534121									
??????	6-52001		???????? 11				Wash from 1490, Main view			
.		Alias		S			.			(Euro)
0125	0L0991	502697501					COVERING			25.78
0127	0L0853	503603601					FOOT WITH FRAME	Not for steam version		110.60
0127	0L1514	503615701					FOOT; ASSY; NEWRT	For steam version		124.80
0129	0L0874	541613001			D	CGX200 8-18	CURTAIN; NEWRT	Up to Ser. Nr.: 835		54.81
0130	0L0997	805662800					SUPPORT; FOR CURTAIN			12.36
0131	0L0873	514699200		S			CURTAIN AXIS; L=490	Up to Ser. Nr.: 835		15.86
0132	0L0850	541612302	0L3207	S			CURTAIN; DOUBLE; 580X490 MM	Up to Ser. Nr.: 928		
0132	0L1732	541617000		S			CURTAIN; DOUBLE; 580X490MM; PVC	From Ser. Nr.: 929		114.70
0133	0L0852	800667800					SUPPORT; SINGLE SHORT CURTAIN			37.86
0134	0E5826	RT0003700		S			CURTAIN AXIS; L=580 MM			16.80
0135	0L0870	505600000					HOOK; CURTAIN	Up to Ser. Nr.: 616		20.91
0135	0L1172	505600001					HOOK; FOR CURTAIN NEWRT	From Ser. Nr.: 617		15.10
0136	0L0851	541612402	0L3208	S			CURTAIN; SINGLE; SHORT; 580X305MM	Up to Ser. Nr.: 928		
0136	0L1733	541617100		S			CURTAIN; SINGLE; PVC	From Ser. Nr.: 929		67.09
0137	0L0871	507687300					HOOK; CURTAIN			13.30
0138	0L0867	503607302					REINFORCEMENT			22.43
0139	0L0859	502696106					RIGHT SIDE; DX			132.00
0140	0L0857	515659300		S			ROLL			6.12
0141	000000									
0142	000000									
0143	0L0828	805662501					SIDE; ASSY INT.	Up to Ser. Nr.: 724		233.50
0143	0L1584	830651401					SIDE PANEL; ASSY	From Ser. Nr.: 725		76.94
0144	0L2968	140600700					HOSE; BY METER; DIA. 8X6MM			2.11
0145	0L0861	541612801		S			DOOR CATCH			2.43
0147	0L0993	541612500					PLUG; PLASTIC			1.02
0150	000000									
0163	0L1471	543631300		S			GASKET; NEWRT			13.62
0164	0L1470	502697402					BRACKET; FOR GASKET NEWRT			12.25
0165	0L1469	503609200					PLAQUE; FOR GASKET NEWRT			3.69
0166	0L1597	565615200					DOOR GASKET; NEWRT			1.68
0168	0L1528	507690700		S			SPRING LATCH			11.41
0170	0L2515	5146A4100		S			PROTECTIVE GRATING	From Ser. Nr.: 147		19.79
0180	0L1642	830632101	0L2595				BASKET GUIDE; ASSY; M1490 NEW RT	Up to Ser. Nr.: 146		
0180	0L2595	835621Z00					BASKET GUIDE; M1490 NEWRT	From Ser. Nr.: 147		245.60
0181	0L2443	W00017300		S			ROLLER; Ø=40MM; H=16MM; WHITE	Up to Ser. Nr.: 146		5.81
0181	0L2520	547604800		S			ROLLER	From Ser. Nr.: 147		6.02

??????	534121									
??????	6-52001		???????? 11				Wash from 1490, Main view			
.		Alias		S			.			(Euro)
0182	0L2174	549646100		S			WASHER	From Ser. Nr.: 147		1.58
0183	0L2522	219614400		S			SNAP RING	From Ser. Nr.: 147		1.02
0184	0L2521	5066A0R00		S			DISC	From Ser. Nr.: 147		4.44
148b	000000									



**PLATON SERVICE**

8 (800) 500-34-41

www.platonservice.com

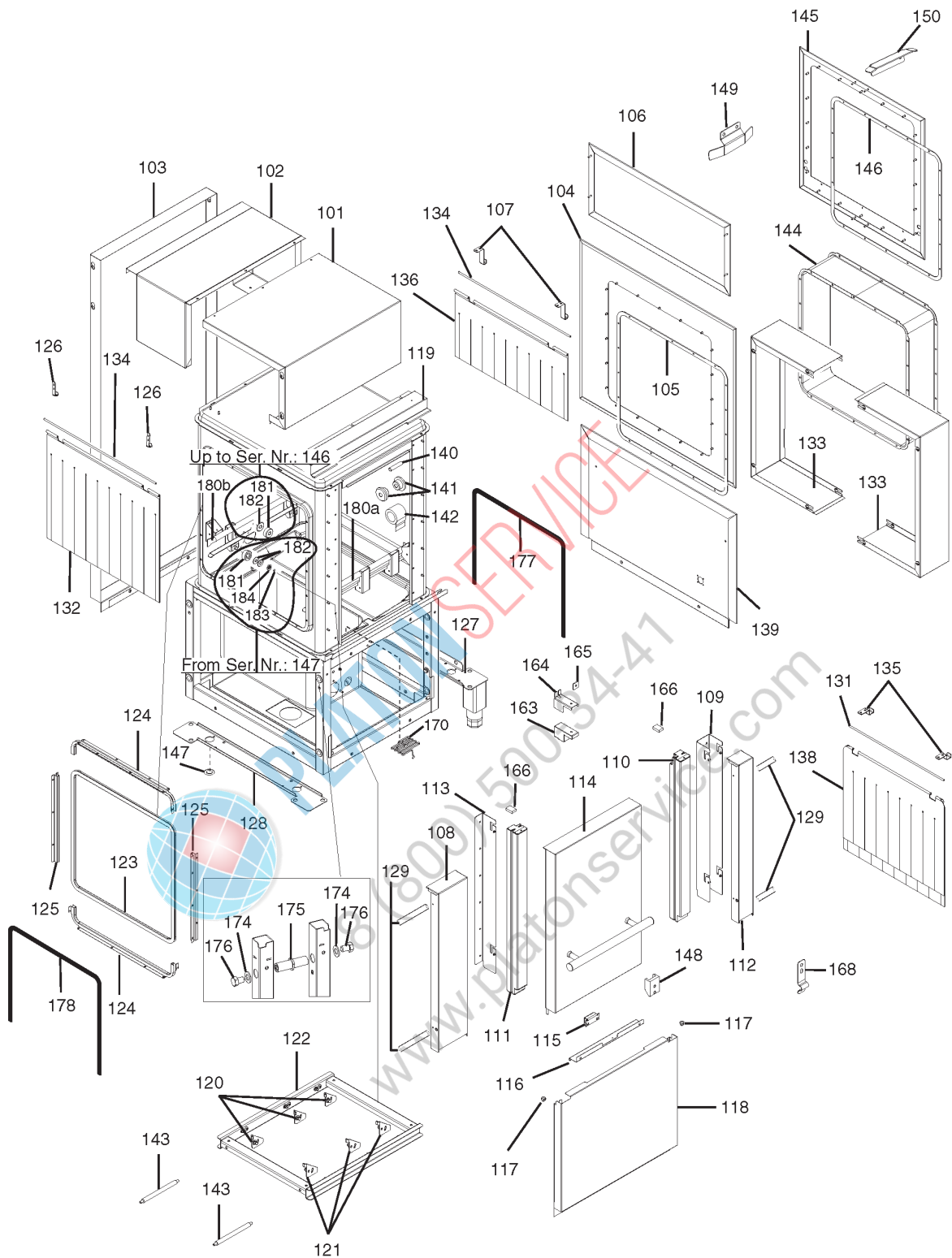

**iii. 652001p4A**

**Prelavaggio da 600, vista generale / Prewash from 600, Main view**

Da Ser.Nr./From Ser.nr.: 544

Page: 14 Ed. 2013-03

**Doc. Nr.: 6-52 001**



??????		534121									
??????		6-52001		???????? 14		Prewash from 600, Main view					
.		Alias		S		.				(Euro)	
0101	0L0823	830652101						COVERING		137.00	
0102	0L0824	830651600						COVERING; FIX		114.70	
0103	0L0825	830652802						BACK PANEL; M600 NEWRT		191.80	
0104	0L0976	830636803						PANEL; ASSY	Right machine	168.50	
0104	0L1179	830636603						PANEL; ASSY INT.	Left machine	168.50	
0105	0L0875	543629700						GASKET		19.43	
0106	0L0828	805662501						SIDE; ASSY INT.	Up to Ser. Nr.: 724	233.50	
0106	0L1584	830651401						SIDE PANEL; ASSY	From Ser. Nr.: 725	76.94	
0107	0L0871	507687300						HOOK; CURTAIN		13.30	
0108	0L0984	830641003						PANEL		80.49	
0109	0L1169	830643200						SUPPORT; FOR PANEL NEWRT	Up to Ser. Nr.: 724	52.98	
0109	0L1169	830643202						SUPPORT; FOR PANEL NEWRT	From Ser. Nr.: 811	52.98	
0109	0L1473	502697703						SUPPORT; FRONT PANEL UPPER	From Ser. Nr.: 725 - Up to Ser. Nr.: 810	52.07	
0110	0L0832	830637101		S				DOOR GUIDE; RH		91.65	
0111	0L0833	830637201		S				DOOR GUIDE; LH		91.65	
0112	0L0856	830641103						PANEL; SLIM		68.31	
0113	0L0862	502697901						SUPPORT; SX	Up to Ser. Nr.: 724	44.05	
0113	0L1049	830643001						SUPPORT; ASSY; SX NEWRT	From Ser. Nr.: 811	34.92	
0113	0L1474	502697902						SUPPORT; SX NEWRT	From Ser. Nr.: 725 - Up to Ser. Nr.: 810	108.60	
0114	0L0837	835620302						DOOR ASSEMBLY		482.10	
0115	0E2898	W00143601		S				SPRING RETAINER		14.89	
0116	0L1168	504696703						SPLASH GUARD; M600 NEWRT		15.62	
0117	0L0839	549644800						PEG		2.84	
0118	0L0840	503601302						PANEL; LOWER		128.90	
0119	0L0830	503604200	0L1176					CRANKCASE	Up to Ser. Nr.: 616		
0119	0L1176	503604203						PROTECTION; M600	From Ser. Nr.: 617	51.77	
0120	0L0842	504696100	0L1314		D			TOOTH; DX	Up to Ser. Nr.: 638		
0120	0L1314	5046A3800		S				TOOTH; DX	From Ser. Nr.: 639	16.03	
0121	0L0843	504696200	0L1315		D			TOOTH; SX	Up to Ser. Nr.: 638		
0121	0L1315	5046A3900		S				TOOTH; SX	From Ser. Nr.: 639	16.03	
0122	0L0977	830636902	0L1305					SLIDE; ASSY	Up to Ser. Nr.: 638		
0122	0L1305	830636905						FEEDING LADDER; M600 PREWASH NEWRT	From Ser. Nr.: 639	263.90	
0123	0L0827	543630300						GASKET		26.59	
0124	0L0992	502697601						COVERING; NEWRT		36.24	
0125	0L0991	502697501						COVERING		25.78	
0126	0L1171	503610500		S				HOOK; NEWRT		15.52	

??????	534121								
??????	6-52001	???????? 14	Prewash from 600, Main view						
.		Alias		S					(Euro)
0127	0L0853	503603601						FOOT WITH FRAME	110.60
0128	0L0854	502696002						SUPPORT; FEET SUPPORT NEWRT	35.73
0129	0L2968	140600700						HOSE; BY METER; DIA. 8X6MM	2.11
0131	0L0873	514699200		S				CURTAIN AXIS; L=490	15.86
0132	0L0850	541612302	0L3207	S				CURTAIN; DOUBLE; 580X490 MM	Up to Ser. Nr.: 928
0132	0L1732	541617000		S				CURTAIN; DOUBLE; 580X490MM; PVC	From Ser. Nr.: 929
0133	0L0887	503605801						COVERING; INLET LATERAL	100.50
0134	0E5826	RT0003700		S				CURTAIN AXIS; L=580 MM	16.80
0135	0L0898	506600400						HOOK	12.62
0136	0L0916	541612202	0L3206					CURTAIN; SHORT DOUBLE	Up to Ser. Nr.: 928
0136	0L1767	541616900		S				CURTAIN; PVC; NEWRT	From Ser. Nr.: 929
0138	0L0917	541612902	0L3209					CURTAIN	Up to Ser. Nr.: 928
0138	0L1765	541617200		S				CURTAIN; PVC; NEWRT	From Ser. Nr.: 929
0139	000000	02696105							
0139	0L0859	5026961055						RIGHT SIDE; DX	132.00
0140	0L0857	515659300		S				ROLL	6.12
0141	0L0858	546631000		S				BUSHING; SPRING SUPPORT	Up to Ser. Nr.: 616
0141	0L1170	546631100		S				BUSHING; FOR SPRING NEWRT	From Ser. Nr.: 617
0142	0E5158	W00093200		S				SPRING; BLADE 25X0, 5 MM	Up to Ser. Nr.: 616
0142	0E5167	W00093300		S				SPRING BLADE; 38X0,5 MM	From Ser. Nr.: 617
0143	0L0841	514695200						SHAFT	18.68
0144	0L0888	503606400						TUNNEL; INLET	170.50
0145	0L0975	830636701						PANEL; ASSY	251.70
0146	0L0920	543631100						GASKET	47.60
0147	0L0993	541612500						PLUG; PLASTIC	1.02
0148	0L0861	541612801		S				DOOR CATCH	2.43
0149	0L1173	502698400						BASKET GUIDE; LAT.M600 PREWASH NEWRT	24.56
0150	0L1200	502698301						BASKET SUPPORT; LOWER	13.09
0163	0L1471	543631300		S				GASKET; NEWRT	13.62
0164	0L1470	502697402						BRACKET; FOR GASKET NEWRT	12.25
0165	0L1469	503609200						PLAQUE; FOR GASKET NEWRT	3.69
0166	0L1597	565615200						DOOR GASKET; NEWRT	1.68
0168	0L1528	507690700		S				SPRING LATCH	11.41
0170	0L2515	5146A4100		S				PROTECTIVE GRATING	From Ser. Nr.: 147
0174	0L2329	206008195						WASHER; DIA.15X28	From Ser. Nr.: 020
0175	0L2324	5146A2401						SPACER	From Ser. Nr.: 020

??????		534121								
??????		6-52001		???????? 14		Prewash from 600, Main view				
.		Alias		S			.		(Euro)	
0176	0L2328	217018205						SCREW; M14X20	From Ser. Nr.: 020	3.24
0177	0L2167	543633J00						GASKET	From Ser. Nr.: 020	30.45
0178	0L2311	543633H00		S				GASKET	From Ser. Nr.: 020	30.45
0181	0L2443	W00017300		S				ROLLER; Ø=40MM; H=16MM; WHITE	Up to Ser. Nr.: 146	5.81
0181	0L2520	547604800		S				ROLLER	From Ser. Nr.: 147	6.02
0182	0L2174	549646100		S				WASHER	From Ser. Nr.: 147	1.58
0183	0L2522	219614400		S				SNAP RING	From Ser. Nr.: 147	1.02
0184	0L2521	5066A0R00		S				DISC	From Ser. Nr.: 147	4.44
180a	0L1705	830637501						BASKET GUIDE; ASSY;DX-SX M600 PW NEWRT	Up to Ser. Nr.: 146	165.40
180a	0L2592	835621W00						BASKET GUIDE; ASSY; M600 PW NEWRT	From Ser. Nr.: 147	214.20
180b	0L1324	830631801	0L2594					BASKET GUIDE; ASSY M600 NEW RT	Up to Ser. Nr.: 146	
180b	0L2594	8306621Y00		S				BASKET GUIDE; ASSY; M600 RINSE NEWRT	From Ser. Nr.: 147	203.00



PLATON SERVICE  
 8 (800) 500-34-41  
 www.platonservice.com

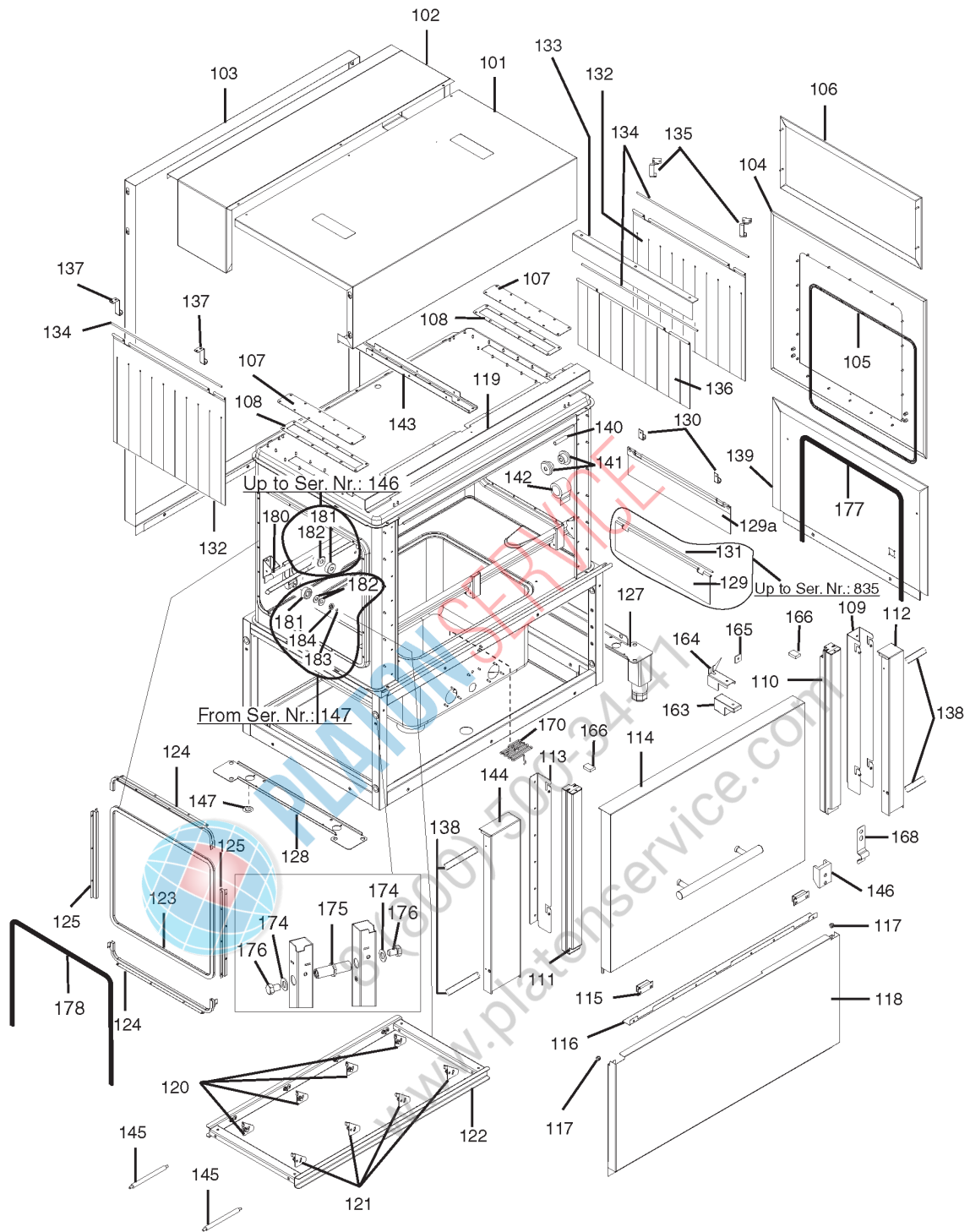

iii. 652001p5A

Prelavaggio da 1165, vista generale/ Prewash from 1165, Main view

Da Ser.Nr./From Ser.nr.: 544

Page: 17 Ed. 2013-03

Doc. Nr.: 6-52 001

?????? 534121  
 ?????? 6-52001 ???????? 17 Prewash from 1165, Main view

.		Alias		S					(Euro)
0101	000000	83065GA00							From Ser. Nr.: 5151
0101	0L0869	830652302					COVERING		Up to Ser. Nr.: 5141 234.50
0102	0L0865	830651700					COVERING; FIX		155.30
0103	0L0864	830653002					BACK PANEL		311.60
0104	0L0880	830638303					PANEL; RH		187.80
0105	0L0875	543629700					GASKET		19.43
0106	0L0828	805662501					SIDE; ASSY INT.	Up to Ser. Nr.: 724	233.50
0106	0L1584	830651401					SIDE PANEL; ASSY	From Ser. Nr.: 725	76.94
0107	0L0877	800667301					PLUG; ASSY		35.02
0108	0L0876	543631001					GASKET		12.57
0109	0L1169	830643200					SUPPORT; FOR PANEL NEWRT	Up to Ser. Nr.: 724	52.98
0109	0L1169	830643202					SUPPORT; FOR PANEL NEWRT	From Ser. Nr.: 811	52.98
0109	0L1473	502697703					SUPPORT; FRONT PANEL UPPER	From Ser. Nr.: 725 - Up to Ser. Nr.: 810	52.07
0110	0L0832	830637101		S			DOOR GUIDE; RH		91.65
0111	0L0833	830637201		S			DOOR GUIDE; LH		91.65
0112	0L0856	830641103					PANEL; SLIM		68.31
0114	0L0881	835620502					DOOR ASSEMBLY		650.00
0115	0E2898	W00143601		S			SPRING RETAINER		14.89
0116	0L0868	504696602					SPLASH GUARD		23.14
0117	0L0839	549644800					PEG		2.84
0118	0L0890	503609901					FRONT PANEL; LOWER		220.30
0119	000000	50361CX00						From Ser. Nr. 5151	
0119	0L0866	503604401	0L1178				CRANKCASE	Up to Ser. Nr.: 616	
0119	0L1178	503610902					PROTECTION; M1165	From Ser. Nr.: 617	61.00
0119	0L1178	503610902					PROTECTION; M1165	Up Ser. Nr. 5141	61.00
0120	0L0842	504696100	0L1314		D		TOOTH; DX		
0120	0L1314	5046A3800		S			TOOTH; DX		16.03
0121	0L0843	504696200	0L1315		D		TOOTH; SX		
0121	0L1315	5046A3900		S			TOOTH; SX		16.03
0122	0L0879	830632400	0L1303				SLIDE	Up to Ser. Nr.: 638	
0122	0L1303	830632403					FEEDING LADDER; M1165 NEW RT	From Ser. Nr.: 639	263.90
0123	0L0827	543630300					GASKET		26.59
0124	0L0992	502697601					COVERING; NEWRT		36.24
0125	0L0991	502697501					COVERING		25.78
0127	0L0853	503603601					FOOT WITH FRAME		110.60
0128	0L0854	502696002					SUPPORT; FEET SUPPORT NEWRT		35.73

??????		534121									
??????		6-52001		???????? 17		Prewash from 1165, Main view					
.		Alias		S			.			(Euro)	
0129	0L0874	541613001			D		CGX200 8-18	CURTAIN; NEWRT	Up to Ser. Nr.: 835	54.81	
0130	0L0955	805662800						HOOK; FOR CURTAIN		12.04	
0131	0L0873	514699200		S				CURTAIN AXIS; L=490	Up to Ser. Nr.: 835	15.86	
0132	0L0850	541612302	0L3207	S				CURTAIN; DOUBLE; 580X490 MM	Up to Ser. Nr.: 928		
0132	0L1732	541617000		S				CURTAIN; DOUBLE; 580X490MM; PVC	From Ser. Nr.: 929	114.70	
0133	0L0852	800667800						SUPPORT; SINGLE SHORT CURTAIN		37.86	
0134	0E5826	RT0003700		S				CURTAIN AXIS; L=580 MM		16.80	
0135	0L0870	505600000						HOOK; CURTAIN	Up to Ser. Nr.: 616	20.91	
0135	0L1172	505600001						HOOK; FOR CURTAIN NEWRT	From Ser. Nr.: 617	15.10	
0136	0L0851	541612402	0L3208	S				CURTAIN; SINGLE; SHORT; 580X305MM	Up to Ser. Nr.: 928		
0136	0L1733	541617100		S				CURTAIN; SINGLE; PVC	From Ser. Nr.: 929	67.09	
0137	0L0871	507687300						HOOK; CURTAIN		13.30	
0138	0L2968	140600700						HOSE; BY METER; DIA. 8X6MM		2.11	
0139	0L0859							RIGHT SIDE; DX		132.00	
0140	0L0857	515659300		S				ROLL		6.12	
0141	0L0858	546631000		S				BUSHING; SPRING SUPPORT	Up to Ser. Nr.: 616	9.29	
0141	0L1170	546631100		S				BUSHING; FOR SPRING NEWRT	From Ser. Nr.: 617	7.18	
0142	0E5158	W00093200		S				SPRING; BLADE 25X0, 5 MM	Up to Ser. Nr.: 616	49.74	
0142	0E5167	W00093300		S				SPRING BLADE; 38X0,5 MM	From Ser. Nr.: 617	56.10	
0143	0L0867	503607302						REINFORCEMENT		22.43	
0144	0L0984	830641003						PANEL		80.49	
0145	0L0841	514695200						SHAFT		18.68	
0146	0L0861	541612801		S				DOOR CATCH		2.43	
0147	0L0993	541612500						PLUG; PLASTIC		1.02	
0163	0L1471	543631300		S				GASKET; NEWRT		13.62	
0164	0L1470	502697402						BRACKET; FOR GASKET NEWRT		12.25	
0165	0L1469	503609200						PLAQUE; FOR GASKET NEWRT		3.69	
0166	0L1597	565615200						DOOR GASKET; NEWRT		1.68	
0168	0L1528	507690700		S				SPRING LATCH		11.41	
0170	0L2515	5146A4100		S				PROTECTIVE GRATING	From Ser. Nr.: 147	19.79	
0174	0L2329	206008195						WASHER; DIA.15X28	From Ser. Nr.: 020	1.02	
0175	0L2324	5146A2401						SPACER	From Ser. Nr.: 020	20.00	
0176	0L2328	217018205						SCREW; M14X20	From Ser. Nr.: 020	3.24	
0177	0L2167	543633J00						GASKET	From Ser. Nr.: 020	30.45	
0178	0L2311	543633H00		S				GASKET	From Ser. Nr.: 020	30.45	
0180	0L1704	830632001	0L2593					BASKET GUIDE; ASSY; M1165 NEWRT	Up to Ser. Nr.: 146		

?????? 534121  
 ?????? 6-52001 ???????? 17 Prewash from 1165, Main view

.		Alias		S			.			(Euro)
0180	0L2593	835621X00						BASKET GUIDE; ASSY; M1165 NEWRT	From Ser. Nr.: 147	234.50
0181	0L2443	W00017300		S				ROLLER; Ø=40MM; H=16MM; WHITE	Up to Ser. Nr.: 146	5.81
0181	0L2520	547604800		S				ROLLER	From Ser. Nr.: 147	6.02
0182	0L2174	549646100		S				WASHER	From Ser. Nr.: 147	1.58
0183	0L2522	219614400		S				SNAP RING	From Ser. Nr.: 147	1.02
0184	0L2521	5066A0R00		S				DISC	From Ser. Nr.: 147	4.44



**PLATON SERVICE**

8 (800) 500-34-41

www.platonservice.com

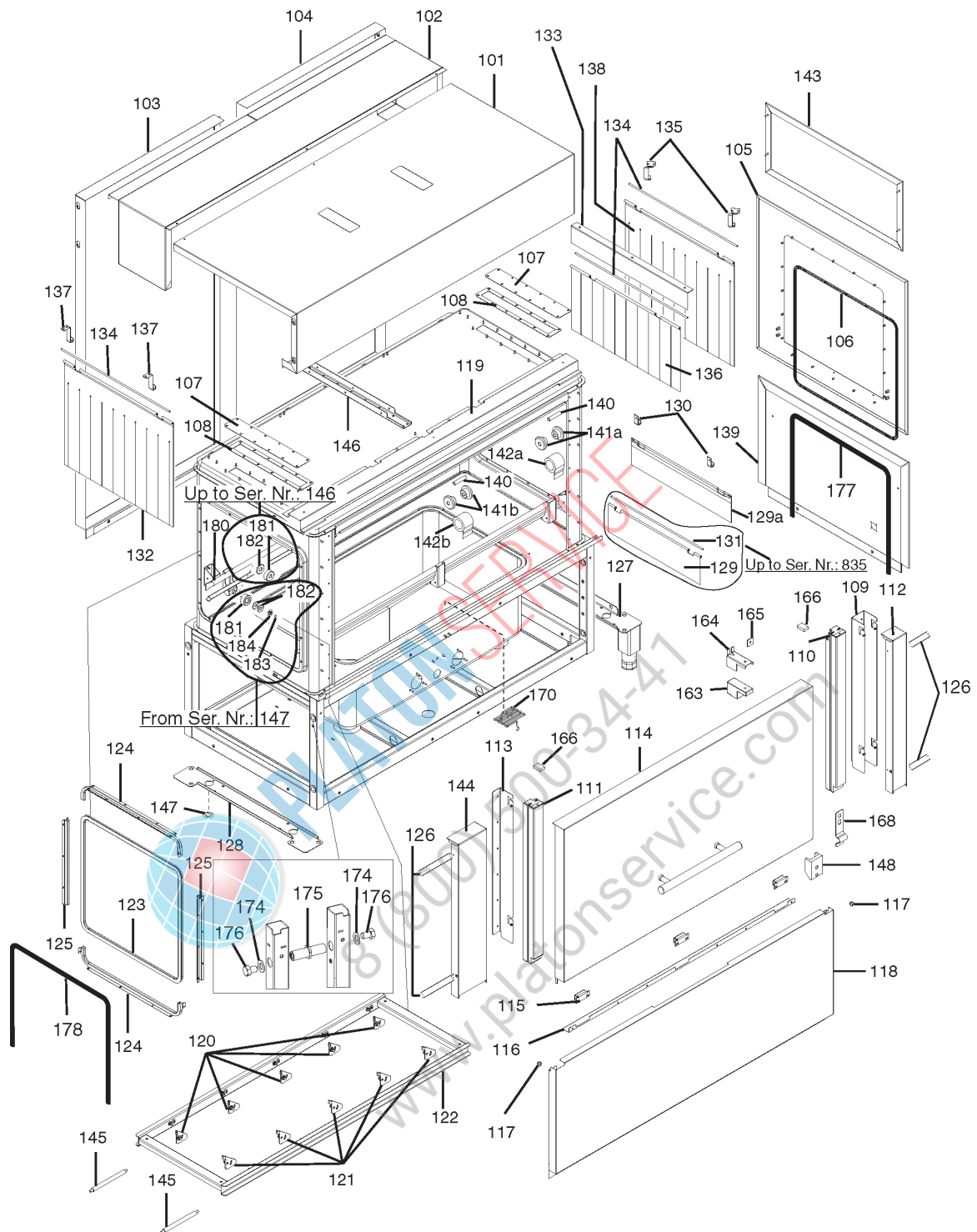

iii. 652001p6A

Prelavaggio da 1490, vista generale/ Prewash from 1490, Main view

Da Ser.Nr./From Ser.nr.: 544

Page: 20 Ed. 2013-03

Doc. Nr.: 6-52 001



?????? 534121									
?????? 6-52001 ???????? 20 Prewash from 1490, Main view									
.		Alias		S					(Euro)
0101	000000	83065GB00							From Ser. Nr.: 5151
0101	0L0897	830652402						COVER PLATE	Up to Ser. Nr.: 5141 268.00
0102	0L0885	830651800						COVERING	169.50
0103	0L0889	830653200						BACK PANEL; SX	180.70
0104	0L0884	830653102						BACK PANEL	176.60
0105	0L0880	830638303						PANEL; RH	187.80
0106	0L0875	543629700						GASKET	19.43
0107	0L0877	800667301						PLUG; ASSY	35.02
0108	0L0876	543631001						GASKET	12.57
0109	0L1169	830643200						SUPPORT; FOR PANEL NEWRT	Up to Ser. Nr.: 724 52.98
0109	0L1169	830643202						SUPPORT; FOR PANEL NEWRT	From Ser. Nr.: 811 52.98
0109	0L1473	502697703						SUPPORT; FRONT PANEL UPPER	From Ser. Nr.: 725 - Up to Ser. Nr.: 810 52.07
0110	0L0833	830637201		S				DOOR GUIDE; LH	91.65
0111	0L0832	830637101		S				DOOR GUIDE; RH	91.65
0112	0L0856	830641103						PANEL; SLIM	68.31
0113	0L0862	502697901						SUPPORT; SX	Up to Ser. Nr.: 724 44.05
0113	0L1049	830643001						SUPPORT; ASSY; SX NEWRT	From Ser. Nr.: 811 34.92
0113	0L1474	502697902						SUPPORT; SX NEWRT	From Ser. Nr.: 725 - Up to Ser. Nr.: 810 108.60
0114	0L0989	835620602						DOOR ASSEMBLY	715.00
0115	0E2898	W00143601		S				SPRING RETAINER	14.89
0116	0L0896	504696502						SPLASH GUARD; 1211MM	41.62
0117	0L0839	549644800						PEG	2.84
0118	0L0891	503610001						FRONT PANEL; LOWER M1490	233.50
0119	000000	50361CY00							From Ser. Nr.: 5151
0119	0L0886	503604501	0L1177					CRANKCASE	Up to Ser. Nr.: 616
0119	0L1177	503614102						PROTECTION; M1490; 1489MM	From Ser. Nr.: 617 61.51
0119	0L1177	503614102						PROTECTION; M1490; 1489MM	Up to Ser. Nr.: 5141 61.51
0120	0L0842	504696100	0L1314		D			TOOTH; DX	Up to Ser. Nr.: 638
0120	0L1314	5046A3800		S				TOOTH; DX	From Ser. Nr.: 639 16.03
0121	0L0843	504696200	0L1315		D			TOOTH; SX	Up to Ser. Nr.: 638
0121	0L1315	5046A3900		S				TOOTH; SX	From Ser. Nr.: 639 16.03
0122	0L0956	830632500	0L1304					SLIDE	Up to Ser. Nr.: 638
0122	0L1304	830632503						FEEDING LADDER; M1490 NEW RT	From Ser. Nr.: 639 308.60
0123	0L0827	543630300						GASKET	26.59
0124	0L0992	502697601						COVERING; NEWRT	36.24
0125	0L0991	502697501						COVERING	25.78

???????		534121									
???????		6-52001		????????? 20		Prewash from 1490, Main view					
.		Alias		S			.				(Euro)
0126	0L2968	149600700							HOSE; BY METER; DIA. 8X6MM		2.11
0127	0L0853	503603601							FOOT WITH FRAME		110.60
0128	0L0854	502696002							SUPPORT; FEET SUPPORT NEWRT		35.73
0129	0L0874	541613001			D		CGX200 8-18		CURTAIN; NEWRT	Up to Ser. Nr.: 835	54.81
0130	0L0955	805662800							HOOK; FOR CURTAIN		12.04
0131	0L0873	514699200		S					CURTAIN AXIS; L=490	Up to Ser. Nr.: 835	15.86
0132	0L0850	541612302	0L3207	S					CURTAIN; DOUBLE; 580X490 MM	Up to Ser. Nr.: 928	
0132	0L1732	541617000		S					CURTAIN; DOUBLE; 580X490MM; PVC	From Ser. Nr.: 929	114.70
0133	0L0852	800667800							SUPPORT; SINGLE SHORT CURTAIN		37.86
0134	0E5826	RT0003700		S					CURTAIN AXIS; L=580 MM		16.80
0135	0L0870	505600000							HOOK; CURTAIN	Up to Ser. Nr.: 616	20.91
0135	0L1172	505600001							HOOK; FOR CURTAIN NEWRT	From Ser. Nr.: 617	15.10
0136	0L0851	541612402	0L3208	S					CURTAIN; SINGLE; SHORT; 580X305MM	Up to Ser. Nr.: 928	
0136	0L1733	541617100		S					CURTAIN; SINGLE; PVC	From Ser. Nr.: 929	67.09
0137	0L0871	507687300							HOOK; CURTAIN		13.30
0138	000000										
0139	0L0859	502696105							RIGHT SIDE; DX		132.00
0140	0L0857	515659300		S					ROLL		6.12
0141	000000										
0142	000000										
0143	0L0828	805662501							SIDE; ASSY INT.	From Ser. Nr.: 724	233.50
0143	0L1584	830651401							SIDE PANEL; ASSY	From Ser. Nr.: 725	76.94
0144	0L0984	830641003							PANEL		80.49
0145	0L0841	514695200							SHAFT		18.68
0146	0L0867	503607302							REINFORCEMENT		22.43
0147	0L0993	541612500							PLUG; PLASTIC		1.02
0148	0L0861	541612801		S					DOOR CATCH		2.43
0163	0L1471	543631300		S					GASKET; NEWRT		13.62
0164	0L1470	502697402							BRACKET; FOR GASKET NEWRT		12.25
0165	0L1469	503609200							PLAQUE; FOR GASKET NEWRT		3.69
0166	0L1597	565615200							DOOR GASKET; NEWRT		1.68
0168	0L1528	507690700		S					SPRING LATCH		11.41
0170	0L2515	5146A4100		S					PROTECTIVE GRATING	From Ser. Nr.: 147	19.79
0174	0L2329	206008195							WASHER; DIA.15X28	From Ser. Nr.: 020	1.02
0175	0L2324	5146A2401							SPACER	From Ser. Nr.: 020	20.00
0176	0L2328	217018205							SCREW; M14X20	From Ser. Nr.: 020	3.24

??????	534121									
??????	6-52001		???????? 20					Prewash from 1490, Main view		
.		Alias		S			.			(Euro)
0177	0L2167	543633J00						GASKET	From Ser. Nr.: 020	30.45
0178	0L2311	543633H00		S				GASKET	From Ser. Nr.: 020	30.45
0180	0L1642	830632101	0L2595					BASKET GUIDE; ASSY; M1490 NEW RT	Up to Ser. Nr.: 146	
0180	0L2595	835621Z00						BASKET GUIDE; M1490 NEWRT	From Ser. Nr.: 147	245.60
0181	0L2443	W00017300		S				ROLLER; Ø=40MM; H=16MM; WHITE	Up to Ser. Nr.: 146	5.81
0181	0L2520	547604800		S				ROLLER	From Ser. Nr.: 147	6.02
0182	0L2174	549646100		S				WASHER	From Ser. Nr.: 147	1.58
0183	0L2522	219614400		S				SNAP RING	From Ser. Nr.: 147	1.02
0184	0L2521	5066A0R00		S				DISC	From Ser. Nr.: 147	4.44



PLATON SERVICE

8 (800) 500-34-47

www.platonservice.com

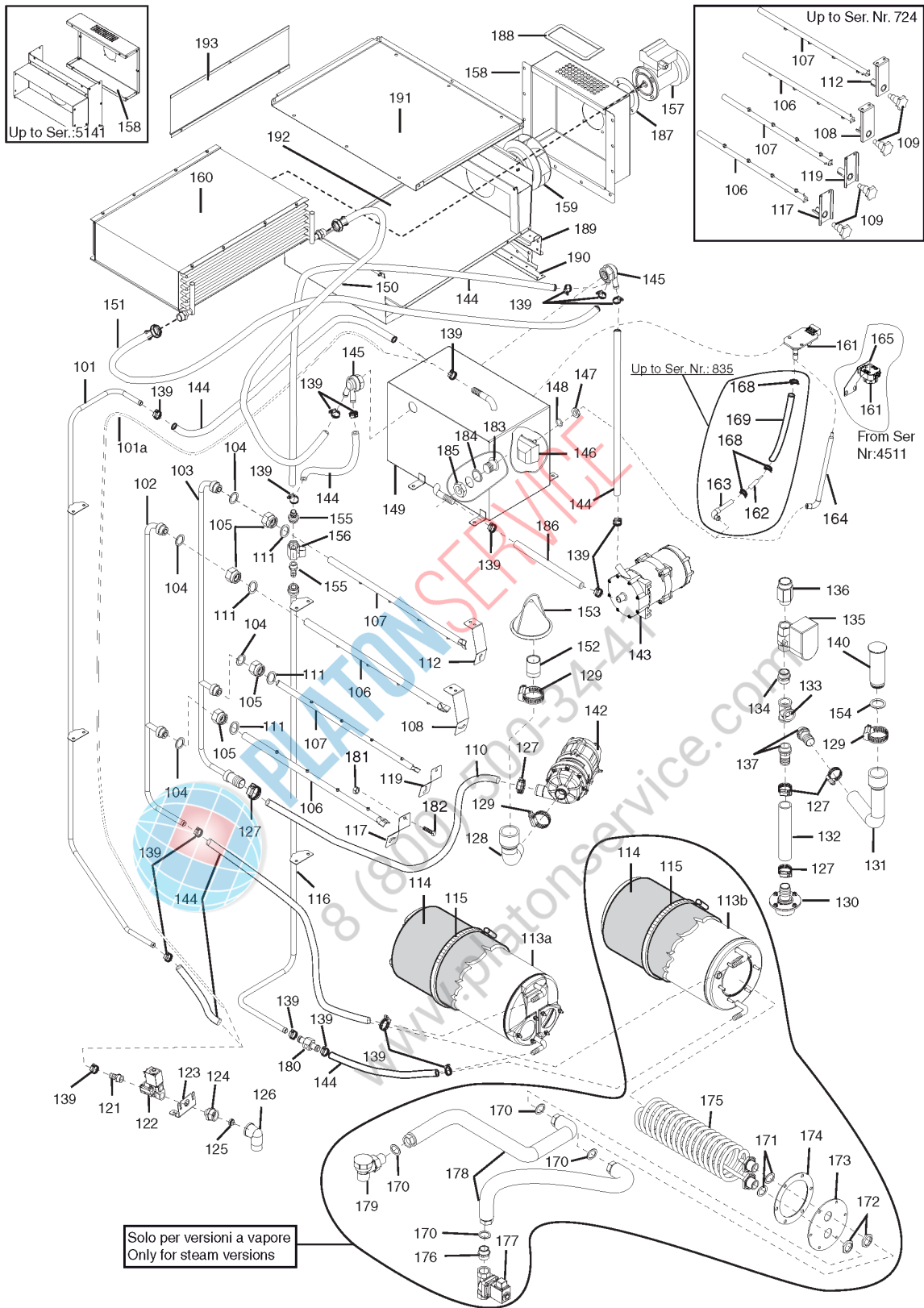

ill. 652001p7

Risciacquo da 600, Circuito Idraulico/ Rinse from 600, Hydraulic circuit

Da Ser.Nr./From Ser.nr.: 544

Page: 23 Ed. 2016-07

Doc. Nr.: 6-52 001

??????	534121									
??????	6-52001		???????? 23				Rinse from 600, Hydraulic circuit			
.		Alias		S			.			(Euro)
0101	0L0982	830639101					TUBE; STEEL ASSY	Up to Ser. Nr.: 928		110.60
0102	0L0979	830637601					TUBE; ASSY STEEL	Up to Ser. Nr.: 928		119.80
0102	0L1287	830648900					RINSE PIPE; NEW RT	From Ser. Nr.: 929		55.42
0103	0L0980	830637701					WATER PIPE			58.57
0104	0E5122	W00500800	0L2402				GASKET	Up to Ser.Nr.: 045		
0104	0L2402	569608800		S			GASKET; 29X21MM	From Ser.Nr.: 046		3.28
0105	0L0907	514698201		S			NUT			86.38
0106	0L0966	830634001					RINSE ARM	Up to Ser. Nr.: 724		48.82
0106	0L1467	830650900					RINSE ARM; ASSY	From Ser. Nr.: 725 - Up to Ser. Nr.: 146 - Not for WTM140		85.87
0106	0L1468	830651100					WASH ARM; ASSY; NEWRT	From Ser. Nr.: 725 - Up to Ser. Nr.: 146 - For WTM140		50.75
0106	0L2529	830657M00					WASH ARM	From Ser. Nr.: 147 - For WTM140		54.20
0106	0L2631	830657N00		S			RINSE ARM	From Ser. Nr.:147 - Not for WTM140		54.20
0107	0L0967	830634201					ARM; ASSY;DUO	Up to Ser. Nr.: 724		64.35
0107	0L1466	830651000		S			WASH ARM; ASSY; DUO NEWRT	From Ser. Nr.: 725 - Up to Ser. Nr.: 146		85.87
0107	0L2633	830657P00					WASH ARM	From Ser. Nr.: 147		54.20
0108	0L0970	830634500					SUPPORT; ASSY	Up to Ser. Nr.: 724		87.19
0108	0L1462	5056A0700					SPRING; UPPER; NEWRT	From Ser. Nr.: 725 - Up to Ser. Nr.: 146		21.72
0108	0L2517	5056A1H00					UPPER SPRING	From Ser. Nr.: 147		19.18
0109	0L0929	544635300					KNOB	Up to Ser. Nr.: 724		86.88
0110	049773	140066100		S			HOSE; 25,5X36MM; L=1000MM			28.42
0111	0E5118	W00524500		S			O-RING; DI=17,3MM; DE=22,1MM			1.02
0112	0L0971	830634600					SUPPORT; DUO	Up to Ser. Nr.: 724		50.24
0112	0L1464	5056A0900					UPPER SPRING	From Ser. Nr.: 725 - Up to Ser. Nr.: 146		20.16
0112	0L2636	5056A1K00					UPPER SPRING	From Ser. Nr.: 147		19.64
0114	049863	569606600		S			INSULATION FOR BOILER; 670X450X13			22.03
0115	0L2551	518684F00					CLAMP; 200-220 H12MM			14.46
0116	048531	140066039		S			RUBBER HOSE; ØI=12MM;ØE=19,5MM;BY METER	From Ser. Nr.: 929		9.55
0116	0L0983	830639201					TUBE; FOR BOILER	Up to Ser. Nr.: 928		74.60
0117	0L0968	830634300					SUPPORT; RINSE LOWER	Up to Ser. Nr.: 724		73.99
0117	0L1463	5056A0800					SPRING; LOWER; NEWRT	From Ser. Nr.: 725 - Up to Ser. Nr.: 146		21.01
0117	0L2518	5056A1J00					LOWER SPRING	From Ser. Nr.: 147		19.18
0119	0L0969	830634400					SUPPORT; DUO LOWER ARM	Up to Ser. Nr.: 724		45.98
0119	0L1465	5056A1000					LOWER SPRING	From Ser. Nr.: 725 - Up to Ser. Nr.: 146		110.60
0119	0L2637	5056A1L00					LOWER SPRING	From Ser. Nr.: 147		19.64
0121	0L0477	514694300					RUBBER HOLDER; USA			14.79

??????		534121									
??????		6-52001		???????? 23		Rinse from 600, Hydraulic circuit					
.		Alias		S			.			(Euro)	
0122	0L2516	696618500		S				SOLENOID VALVE; 3/8' 24V 50/60HZ		94.46	
0123	0L0899	507690601						BRACKET		9.82	
0124	0L0479	515655400		S				NIPPLE; USA		17.21	
0125	0L0178	549642800		S				PRESSURE REDUCER; 20L/MIN; ORANGE		4.22	
0126	049679	544628400						ELBOW		19.98	
0127	047578	518604001		S				CLAMP; 26-38		1.80	
0128	0L0937	544681500						PUMP SUCTION PIPE		19.69	
0129	046878	518602701		S				HOSE CLAMP; 35-50/9		1.91	
0130	0L0938	544681600						WATER DRAIN FITTING		7.29	
0131	0L0931	544635800						OWERFLOW PIPE		19.49	
0132	049287	140066043		S				HOSE; ØE=30MM; ØI=25MM; L=430MM		10.39	
0133	0E5522	W00528200						NIPPLE T; 3/4" F		18.88	
0134	072457	W00526300		S				NIPPLE		10.04	
0135	0L0949	696616600		S				MOTORIZED SOLENOID VALVE; 24V 50/60HZ		154.30	
0136	0L0906	514697701						REDUCTION NIPPLE		41.21	
0137	0E2594	W00502900		S				HOSE NIPPLE		12.57	
0139	048126	518609801		S				CLIP; 13-20		1.58	
0140	0L0904	514696201						OWERFLOW PIPE		77.85	
0142	0L0947	611630600		S				RINSE PUMP; ; 400V/3PH./50HZ		156.30	
0143	0L1384	611634600		S				PUMP; 400V 50HZ 0.45HP		217.20	
0144	048531	140066039		S				RUBBER HOSE; ØI=12MM;ØE=19,5MM;BY METER		9.55	
0145	049332	544625400	0L1892					VALVOLA NON RITORNO; DVGW	Up to Ser. Nr.: 835		
0145	0L1892	544685800		S				NONRETURN VALVE; HIGH TEMPERATURE	From Ser. Nr.: 836	18.09	
0146	048308	542604901		S				AIR TRAP; FOR PRESSURE GAUGE		4.44	
0147	049268	544623800		S				HEX NUT; M14X1,5		1.80	
0148	068642	246035800		S				O-RING; ØI=15,54X2,62		1.02	
0149	000000	83065F900							From Ser. Nr: 4511		
0149	0L0900	509610601						AIR GAP	Up to Ser. Nr.: 616	215.20	
0149	0L1174	509610602						AIR GAP	From Ser. Nr.: 617	204.00	
0149	0L1174	509610602						AIR GAP	Up to Ser Nr: 4501	204.00	
0150	0L0988	830642900						DRAIN HOSE; L=2450MM		32.99	
0151	0L0987	830642800						FEEDER HOSE; L=1450MM		26.69	
0152	0E5518	W00103300						STRAINER HUB		19.59	
0153	0E5186	W00108901		S				STRAINER		83.43	
0154	0L1277	543633300		S				O-RING; 26,58X2,53		1.02	

??????	534121									
??????	6-52001		???????? 23				Rinse from 600, Hydraulic circuit			
.		Alias		S			.			(Euro)
0155	0L0040	514692200		S			RUBBER HOLDER			16.47
0156	0L1351	514600200					TAP; FEED REGULATOR			22.43
0157	0L0946	611630400		S			FAN MOTOR			190.80
0158	0L0952	800668201					MOTOR BRACKET; CU NEWRT	Up to Ser. Nr: 5141		359.30
0158	0L3569	541618H00			D		IMPELLER COVER FOR MOTOR; NEW CU	From Ser Nr: 5151		99.47
0158	0L3569	541618H00			D		IMPELLER COVER FOR MOTOR; NEW CU	Up to Ser Nr: 6261		99.47
0158	0L3765	83065P200						From Ser Nr: 6271		
0159	0L0941	549644900					FAN BLADE			179.70
0160	0L0902	511620000	0L1730				HEAT EXCHANGER	Up to Ser. Nr: 5141		
0160	0L3573	511621200					HEAT EXCHANGER; FOR ESD	From Ser Nr: 5151		680.00
0161	0L1132	673608302		S			PCB; PRESSUR SENSOR	Up to Ser. Nr: 4501		58.67
0161	0L2845	673611M00		S			ANALOGIC SENSOR	From Ser Nr: 4511		17.73
0162	0L1530	544681701			D	CGX200 8-16	REDUCER	Up to Ser. Nr.: 835		6.47
0164	0L1909	544685A00		S			AIR TRAP TUBE	Up to Ser. Nr: 4501		16.36
0164	0L3088	544688D00					PRESSURE SWITCH HOSE	From Ser. Nr: 4511		3.91
0165	0L3302	5056A2M01			D		PRESSURE SWITCH SUPPORT	From Ser Nr: 4511		12.86
0168	0L0082	518613000		S			CLAMP; DIA. 7,3-7,8MM	Up to Ser. Nr.: 835		1.02
0168	0L0083	518613800		S			CLAMP; 9,9/9,3	From Ser. Nr.:4511		1.02
0169	0L1577	544630001		S			SILICONE HOSE; DIA 4 MM; BY METER	Up to Ser. Nr.: 835		4.75
0170	0L1560	543633500	0L2236				GASKET; 17X24X2; NEWRT	Up to Ser. Nr.: 019		
0170	0L2236	543633L00		S			GASKET; SP.2,8MM	From Ser. Nr.: 020		10.45
0171	0L1561	543633600	0L1564	S			O-RING; 29.82X2.62			
0172	0E5056	W00525500					NUT			12.13
0173	0L1599	5046A4100					FLANGE; NEWRT			23.35
0174	0L1559	543633401					GASKET			20.06
0175	0L1554	515663800					STEAM COIL; FOR BOILER NEWRT			284.20
0176	072457	W00526300		S			NIPPLE			10.04
0177	0L1481	696617600					STEAM ELECTRIC VALVE; 24V-50HZ			276.10
0178	0L1558	515664500					HOSE FLEXIBLE; STAINLESS STEEL; L=610 MM			68.01
0179	0E0153	W00513200					STEAM TRAP			232.40
0180	0E3080	W00502600		S			HOSE NIPPLE			18.27
0181	0TH077	218574005	034496	S			NUT; HEX M6	From Ser. Nr.: 147		
0182	0L2413	217014145					SCREW; SET 100PCS; M6X14	From Ser. Nr.: 147		20.30
0183	0L3493	5146A8100					PLUG; 1/4" GAS	From Ser Nr:4511		16.41
0184	0L2305	543633X00		S			O-RING; DIA.2,62X15,54	From Ser Nr:4511		1.02
0185	0H2610	W00525300		S			WASHER	From Ser Nr:4511		4.91

?????? 534121  
 ?????? 6-52001 ???????? 23 Rinse from 600, Hydraulic circuit

.		Alias		S		.			(Euro)	
0186	0L2045	544685B00						PUMP SUCTION PIPE	From Ser Nr:4511	27.10
0187	0L3570	543635S00						MOTOR GASKET; NEW CU	From Ser Nr: 5151	5.18
0188	0L0689	140036014	046583	S				ELASTOMER GASKET; BY METER	From Ser Nr: 5151	2.03
0189	0L3567	83065D800			D			BASE ASSEMBLY SUPPORT CU; ASSY	From Ser Nr: 5151	48.72
0190	0L3568	83065D901			D			CROSSPIECE; ASSY	From Ser Nr: 5151	46.69
0191	0L3560	5046AB901			D			LID; CU NEWRT	From Ser Nr: 5151	93.38
0192	0L3566	83065D600			D			BATTERY ASSEMBLY SUPPORT; ASSY	From Ser Nr: 5151	249.70
0193	0L3561	83065DD01			D			COVERING; ASSY; CU NEWRT	From Ser Nr: 5151	56.84
113a	0L0990	850656900		S				BOILER; ASSY	Up to Ser. Nr.: : 851	229.40
113a	0L0990	850656901		S				BOILER; ASSY	From Ser. Nr.: 022	229.40
113a	0L1955	850663700	0L0990					BOILER; ASSY; NEWRT	From Ser. Nr.: 852 - Up to Ser. Nr.: 021	
113b	0L1562	830649500	0L1960					BOILER; ASSY; NEWRT	Up to Ser. Nr.: : 851	
113b	0L1562	830649501	0L1960					BOILER; ASSY; NEWRT	From Ser. Nr.: 022	
113b	0L1960	850663600						BOILER; ASSY; NEWRT	From Ser. Nr.: 852 - Up to Ser. Nr.: 021	339.00



PLATON SERVICE  
 8 (800) 500-34-41  
 www.platonservice.com



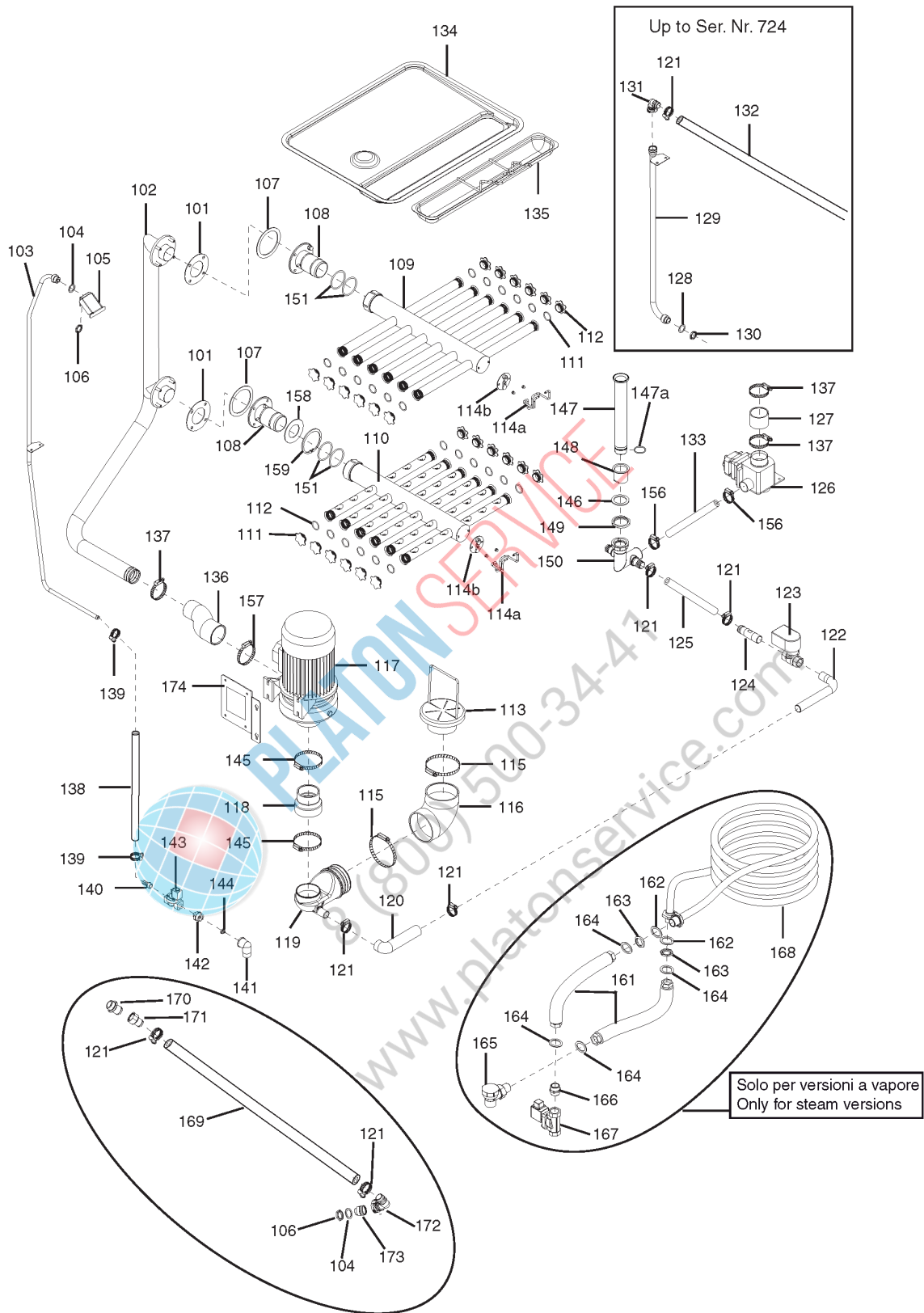

ill. 652001p8A

Lavaggio da 1165, Circuito Idraulico/ Wash from 1165, Hydraulic circuit

Da Ser.Nr./From Ser.nr.: 544

Page: 27 Ed. 2015-06

Doc. Nr.: 6-52 001

??????		534121									
??????		6-52001		???????? 27		Wash from 1165, Hydraulic circuit					
.		Alias		S			.			(Euro)	
0101	0L0919	543629400		S				GASKET		4.65	
0102	0L0957	830632601						WASH PIPE; ASSY	Up to Ser. Nr.: 616	220.30	
0102	0L1187	830632603						TUBE; WASH M1165 NEWRT	From Ser. Nr.: 617	189.80	
0103	0L0981	830637801						FEEDER HOSE	Up to Ser. Nr.: 928	79.17	
0103	0L1508	830649701						FEEDER HOSE; FOR TANK	From Ser. Nr.: 929	48.62	
0104	0E5122	W00500800	0L2402					GASKET	Up to Ser.Nr.: 045		
0104	0L2402	569608800		S				GASKET; 29X21MM	From Ser.Nr.: 046	3.28	
0105	0E5848	RT0011900						SPLASH GUARD		18.37	
0106	000000	218300100									
0107	0L0923	543632400		S				O-RING		1.02	
0108	0L0961	830633100	0L1188					SUPPORT; WASH PIPE	Up to Ser. Nr.: 616		
0108	0L1188	830633101						SUPPORT; FOR WASH TUBE	From Ser. Nr.: 617	139.10	
0109	0L0965	830633402						WASH ARM	Up to Ser. Nr.: 810 - Left machine	943.00	
0109	0L0965	830633502						WASH ARM	Up to Ser. Nr.: 810 - Right machine	943.00	
0109	0L1751	830654500	0L3475					WASH ARM	From Ser. Nr.: 811 - Left machine		
0109	0L1751	830654500	0L3475					WASH ARM	From Ser. Nr.: 811 - Right machine		
0109	0L1751	830654500	0L3475					WASH ARM	Up to Ser. Nr.: 5051 - Left machine		
0109	0L1751	830654500	0L3475					WASH ARM	Up to Ser. Nr.: 5051 - Right machine		
0109	0L3475	83065FY00						WASHING JET; UPPER	From Ser. Nr.: 5061 - Left machine	373.50	
0109	0L3475	83065FY00						WASHING JET; UPPER	From Ser. Nr.: 5061 - Right machine	373.50	
0110	0L0964	830633402						WASH ARM	Up to Ser. Nr.: 810 - Right machine	1,129.00	
0110	0L0964	830633502						WASH ARM	Up to Ser. Nr.: 810 - Left machine	1,129.00	
0110	0L1750	830654400	0L3476					WASH ARM	From Ser. Nr.: 811 - Left machine		
0110	0L1750	830654400	0L3476					WASH ARM	From Ser. Nr.: 811 - Right machine		
0110	0L1750	830654400	0L3476					WASH ARM	Up to Ser. Nr.: 5051 - Left machine		
0110	0L1750	830654400	0L3476					WASH ARM	Up to Ser. Nr.: 5051 - Right machine		
0110	0L3476	83065FZ00						WASHING JET; LOWER	From Ser. Nr.: 5061 - Left machine	373.50	
0110	0L3476	83065FZ00						WASHING JET; LOWER	From Ser. Nr.: 5061 - Right machine	373.50	
0111	0L0922	543632300		S				O-RING; ØI=26,65X2,62 MM		1.02	
0112	0L0978	830637000		S				PLUG; FOR WASH ARMS	Up to Ser. Nr.: 810	22.13	
0112	0L1711	541617400		S				PLUG; FOR WASH ARM	From Ser. Nr.: 811	1.68	
0113	0L0951	800666601						PUMP STRAINER		104.50	
0114	000000										
0115	0L0915	518682700						CLAMP; 100-120		5.29	
0116	0L0930	544635700						SLEEVE		57.35	

??????		534121									
??????		6-52001		???????? 27		Wash from 1165, Hydraulic circuit					
.		Alias		S			.			(Euro)	
0117	0L0942	611629800	0L3036					PUMP; DWO 300; 230/400V 50HZ	Up to Ser. Nr.: 3241		
0117	0L3037	611637R00						PUMP; 5245-CAM 1906	From Ser. Nr.: 3251	769.00	
0118	0L0924	544629200	0L2545					SLEEVE	From Ser. Nr.: 3251		
0118	0L0932	544639500						SUCTION HOSE; SX; DWO300 NEWRT	Up to Ser. Nr.: 3241	7.43	
0119	0L0928	544635200						SUCTION HOSE; SX		13.16	
0120	049880	544631300		S				SLEEVE		13.30	
0121	047578	518604001		S				CLAMP; 26-38		1.80	
0122	0L0910	515660200						ELBOW HOSE		29.03	
0123	0L0949	696616600		S				MOTORIZED SOLENOID VALVE; 24V 50/60HZ		154.30	
0124	0L0912	515660400						TUBE		40.40	
0125	049287	140066043		S				HOSE; ØE=30MM; ØI=25MM; L=430MM		10.39	
0126	0L2506	696618600		S				DRAIN VALVE; 24V 50/60HZ		149.20	
0127	0L0934	544639900		S				SLEEVE		5.61	
0128	0E5122	W00500800	0L2402					GASKET	Up to Ser. Nr.: 724		
0129	0L0986	830641700						INPUT DETERGENT PIPE	Up to Ser. Nr. : 724	161.40	
0130	0E5424	W00525400		S				NUT	Up to Ser. Nr.: 724	4.73	
0131	0L0918	541613400						CLUTCH	Up to Ser. Nr.: 724	8.77	
0132	0L0940	544683200						TUBE; PVC L=2850 D.26EST.	Up to Ser. Nr.: 724	28.42	
0133	0L0939	544683100		S				RUBBER HOSE; L=70MM		11.41	
0134	0L0892	504694300						FILTER		271.00	
0135	0L0973	830634900						FILTER BASKET; ASSY		169.50	
0136	0L0936	544640100						SLEEVE	Up to Ser. Nr.: 1324	39.08	
0136	0L1267	544683300						SLEEVE; ZF523V NEWRT	From Ser. Nr.: 1325	43.44	
0137	046855	518602801		S				HOSE CLAMP; 50-70/9		2.00	
0138	048531	140066039		S				RUBBER HOSE; ØI=12MM;ØE=19,5MM;BY METER	Up to Ser. Nr.: 045	9.55	
0138	049379	140066047		S				HOSE; WRC, 1PC=1130MM	From Ser. Nr.: 046	22.23	
0139	048126	518609801		S				CLIP; 13-20		1.58	
0140	0L0477	514694300						RUBBER HOLDER; USA		14.79	
0141	049679	544628400						ELBOW		19.98	
0142	0L0479	515655400		S				NIPPLE; USA		17.21	
0143	0L2516	696618500		S				SOLENOID VALVE; 3/8' 24V 50/60HZ		94.46	
0144	0L0178	549642800		S				PRESSURE REDUCER; 20L/MIN; ORANGE		4.22	
0145	0L0914	518682600		S				CLAMP		3.91	
0146	065506	246037900		S				GASKET; ØI=42,86X3,53 MM		1.02	
0147	0L0908	515657800		S				OWERFLOW PIPE	Up to Ser. Nr.: 712	58.57	

??????	534121									
??????	6-52001		???????? 27				Wash from 1165, Hydraulic circuit			
.		Alias		S			.			(Euro)
0147	0L1430	515657801	0L2295				OWERFLOW PIPE; NEWRT	From S. Nr. 713 - Up to S. Nr. 019		
0147	0L2295	830657300		S			OWERFLOW PIPE	From Ser. Nr.: 020	11.82	
0148	075624	511607200		S	C		DRAIN		12.32	
0149	066079	215190400		S			RING NUT		24.66	
0150	0L0953	805659801		S			DRAIN MANIFOLD		90.03	
0151	0L1276	543633200		S			O-RING; ØI=50X3 MM		1.47	
0156	0L0193	518614400		S			CLMAP; 40-60/9		2.01	
0157	046853	518602901		S			HOSE CLAMP; 60-80/9		2.53	
0158	0L1185	5026A3000					SHUTTER; M1165 MODULARE NEWRT	From Ser. Nr.: 617	6.76	
0159	0L1189	219065212		S			SNAP RING	From Ser. Nr.: 617	4.28	
0161	0L1557	515664100					HOSE FLEXIBLE; STAINLESS STEEL; L=360 MM		57.25	
0162	0L1561	543633600	0L1564	S			O-RING; 29.82X2.62			
0163	0E5056	W00525500					NUT		12.13	
0164	0L1560	543633500	0L2236				GASKET; 17X24X2; NEWRT	Up to Ser. Nr.: 019		
0164	0L2236	543633L00		S			GASKET; SP.2,8MM	From Ser. Nr.: 020	10.45	
0165	0E0153	W00513200					STEAM TRAP		232.40	
0166	072457	W00526300		S			NIPPLE		10.04	
0167	0L1481	696617600					STEAM ELECTRIC VALVE; 24V-50HZ		276.10	
0168	0L1571	515662800					STEAM COIL; M1165 NEWRT		280.10	
0169	0L2426	140600300					HOSE; BY METER; ØINT20X3 (ØEST=26)	From Ser. Nr.: 046 - Only for 140	13.30	
0169	0L2426	140600300					HOSE; BY METER; ØINT20X3 (ØEST=26)	From Ser. Nr.: 046 - Only for 180	13.30	
0169	0L2426	140600300					HOSE; BY METER; ØINT20X3 (ØEST=26)	From Ser. Nr.: 046 - Only for 250	13.30	
0170	0L2423	5146A3B00					RUBBER HOLDER; MALE; G 1/2"	From Ser. Nr.: 046	24.66	
0171	0L2424	5146A3C00					RUBBER HOLDER; FEMALE; G 1/2"	From Ser. Nr.: 046	24.66	
0172	0L0918	541613400					CLUTCH	From Ser. Nr.: 046	8.77	
0173	0L2425	5146A0100					THREAD QUICK CONNECTION	From Ser. Nr.: 046	20.40	
0174	0L3456	5046A8U00			D		PUMP SUPPORT; FIR 5245-CAM1906	From Ser. Nr.: 3125	33.80	

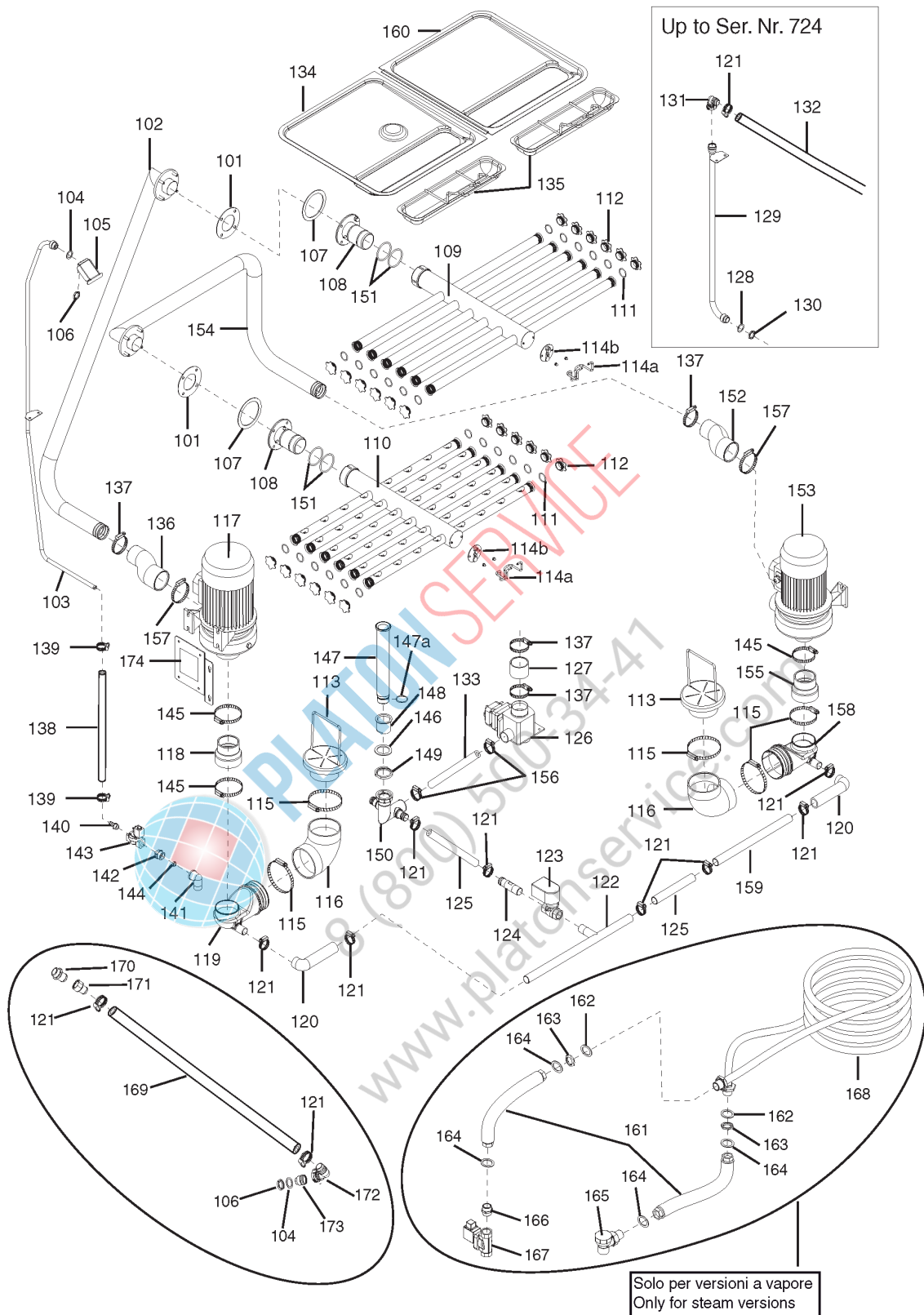

ill. 652001p9

Lavaggio da 1490, Circuito Idraulico/ Wash from 1490, Hydraulic circuit

Da Ser.Nr./From Ser.nr.: 544

Page: 31 Ed. 2015-06

Doc. Nr.: 6-52 001

??????	534121									
??????	6-52001		???????? 31					Wash from 1490, Hydraulic circuit		
.		Alias		S			.			(Euro)
0101	0L0919	543629400		S				GASKET		4.65
0102	0L0960	830632902						WASH ARM; UPPER		151.20
0103	0L0981	830637801						FEEDER HOSE	Up to Ser. Nr.: 928	79.17
0103	0L1508	830649701						FEEDER HOSE; FOR TANK	From Ser. Nr.: 929	48.62
0104	0E5122	W00500800	0L2402					GASKET	Up to Ser.Nr.: 045	
0104	0L2402	569608800		S				GASKET; 29X21MM	From Ser.Nr.: 046	3.28
0105	0E5848	RT0011900						SPLASH GUARD		18.37
0106	000000	218300100								
0107	0L0923	543632400		S				O-RING		1.02
0108	0L0961	830633100	0L1188					SUPPORT; WASH PIPE	Up to Ser. Nr.: 616	
0108	0L1188	830633101						SUPPORT; FOR WASH TUBE	From Ser. Nr.: 617	139.10
0109	0L0963	830633202		D				WASH ARM	Up to Ser. Nr.: 810 - Left machine	826.00
0109	0L0963	830633302		D				WASH ARM	Up to Ser. Nr.: 810 - Right machine	826.00
0109	0L1749	830654200						WASH ARM	From Ser. Nr.: 811 - Left machine	
0109	0L1749	830654300						WASH ARM	From Ser. Nr.: 811 - Right machine	
0109	0L1749	830654300						WASH ARM	Up to Ser. Nr.: 5051 - Left machine	
0109	0L1749	830654300						WASH ARM	Up to Ser. Nr.: 5051 - Right machine	
0109	0L3477	83065G000						WASHING JET; UPPER	From Ser. Nr.: 5061 - Left machine	403.00
0109	0L3477	83065G000						WASHING JET; UPPER	From Ser. Nr.: 5061 - Right machine	403.00
0110	0L0962	830633202		D				WASH ARM	Up to Ser. Nr.: 810 - Right machine	542.00
0110	0L0962	830633302		D				WASH ARM	Up to Ser. Nr.: 810 - Left machine	542.00
0110	0L1748	830654200	0L3478					WASH ARM	From Ser. Nr.: 811 - Right machine	
0110	0L1748	830654200	0L3478					WASH ARM	Up to Ser. Nr.: 5051 - Left machine	
0110	0L1748	830654200	0L3478					WASH ARM	Up to Ser. Nr.: 5051 - Right machine	
0110	0L1748	830654300	0L3478					WASH ARM	From Ser. Nr.: 811 - Left machine	
0110	0L3478	83065G100						WASHING JET; LOWER	From Ser. Nr.: 5061 - Left machine	392.80
0110	0L3478	83065G100						WASHING JET; LOWER	From Ser. Nr.: 5061 - Right machine	392.80
0111	0L0922	543632300		S				O-RING; ØI=26,65X2,62 MM		1.02
0112	0L0978	830637000		S				PLUG; FOR WASH ARMS	Up to Ser. Nr.: 810	22.13
0112	0L1711	541617400		S				PLUG; FOR WASH ARM	From Ser. Nr.: 811	1.68
0113	0L0951	800666601						PUMP STRAINER		104.50
0114	000000									
0115	0L0915	518682700						CLAMP; 100-120		5.29
0116	0L0930	544635700						SLEEVE		57.35
0117	0L0942	611629800	0L3036					PUMP; DWO 300; 230/400V 50HZ	Up to Ser. Nr.: 3241	

??????		534121									
??????		6-52001		???????? 31		Wash from 1490, Hydraulic circuit					
.		Alias		S			.			(Euro)	
0117	0L3037	611637R00						PUMP; 5245-CAM 1906	From Ser. Nr.: 3251	769.00	
0118	0L0924	544629200	0L2545					SLEEVE	From Ser. Nr.: 3251		
0118	0L0932	544639500						SUCTION HOSE; SX; DWO300 NEWRT	Up to Ser. Nr.: 3241	7.43	
0119	0L0928	544635200						SUCTION HOSE; SX		13.16	
0120	049880	544631300		S				SLEEVE		13.30	
0121	047578	518604001		S				CLAMP; 26-38		1.80	
0122	0L0913	515660600						TUBE		41.41	
0123	0L0949	696616600		S				MOTORIZED SOLENOID VALVE; 24V 50/60HZ		154.30	
0124	0L0912	515660400						TUBE		40.40	
0125	049287	140066043		S				HOSE; ØE=30MM; ØI=25MM; L=430MM		10.39	
0126	0L2506	696618600		S				DRAIN VALVE; 24V 50/60HZ		149.20	
0127	0L0934	544639900		S				SLEEVE		5.61	
0128	0E5122	W00500800	0L2402					GASKET	Up to Ser. Nr.: 724		
0129	0L0986	830641700						INPUT DETERGENT PIPE	Up to Ser. Nr.: 724	161.40	
0130	0E5424	W00525400		S				NUT	Up to Ser. Nr.: 724	4.73	
0131	0L0918	541613400						CLUTCH	Up to Ser. Nr.: 724	8.77	
0132	0L0940	544683200						TUBE; PVC L=2850 D.26EST.	Up to Ser. Nr.: 724	28.42	
0133	0L0939	544683100		S				RUBBER HOSE; L=70MM		11.41	
0134	0L0894	504694600						TANK FILTER		250.70	
0135	0L0972	830634800						FILTER BASKET; ASSY		155.30	
0136	0L0936	544640100						SLEEVE	Up to Ser. Nr.: 1324	39.08	
0136	0L1267	544683300						SLEEVE; ZF523V NEWRT	From Ser. Nr.: 1325	43.44	
0137	046855	518602801		S				HOSE CLAMP; 50-70/9		2.00	
0138	048531	140066039		S				RUBBER HOSE; ØI=12MM;ØE=19,5MM;BY METER	Up to Ser. Nr.: 045	9.55	
0138	049379	140066047		S				HOSE; WRC, 1PC=1130MM	From Ser. Nr.: 046	22.23	
0139	048126	518609801		S				CLIP; 13-20		1.58	
0140	0L0477	514694300						RUBBER HOLDER; USA		14.79	
0141	049679	544628400						ELBOW		19.98	
0142	0L0479	515655400		S				NIPPLE; USA		17.21	
0143	0L2516	696618500		S				SOLENOID VALVE; 3/8' 24V 50/60HZ		94.46	
0144	0L0178	549642800		S				PRESSURE REDUCER; 20L/MIN; ORANGE		4.22	
0145	0L0914	518682600		S				CLAMP		3.91	
0146	065506	246037900		S				GASKET; ØI=42,86X3,53 MM		1.02	
0147	0L0908	515657800		S				OWERFLOW PIPE	Up to Ser. Nr.: 712	58.57	
0147	0L1430	515657801	0L2295					OWERFLOW PIPE; NEWRT	From S. Nr. 713 - Up to S. Nr. 019		

??????	534121									
??????	6-52001		???????? 31				Wash from 1490, Hydraulic circuit			
.		Alias		S			.			(Euro)
0147	0L2295	830657300		S				OWERFLOW PIPE	From Ser. Nr.: 020	11.82
0148	075624	511607200		S	C			DRAIN		12.32
0149	066079	215190400		S				RING NUT		24.66
0150	0L0953	805659801		S				DRAIN MANIFOLD		90.03
0151	0L1276	543633200		S				O-RING; ØI=50X3 MM		1.47
0152	0L0936	544640100						SLEEVE		39.08
0153	0L0943	611629902		S				PUMP		621.00
0154	0L0959	830632802						WASH PIPE; LOWER		151.20
0155	0L0924	544629200	0L2545					SLEEVE		
0156	0L0193	518614400		S				CLMAP; 40-60/9		2.01
0157	046853	518602901		S				HOSE CLAMP; 60-80/9		2.53
0158	0L0927	544635100								
0159	0L0912	515660400						TUBE		40.40
0160	0L0893	504694500						TANK FILTER		250.70
0161	0L1557	515664100						HOSE FLEXIBLE; STAINLESS STEEL; L=360 MM		57.25
0162	0L1561	543633600	0L1564	S				O-RING; 29.82X2.62		
0163	0E5056	W00525500						NUT		12.13
0164	0L1560	543633500	0L2236					GASKET; 17X24X2; NEWRT	Up to Ser. Nr.: 019	
0164	0L2236	543633L00		S				GASKET; SP.2,8MM	From Ser. Nr.: 020	10.45
0165	0E0153	W00513200						STEAM TRAP		232.40
0166	072457	W00526300		S				NIPPLE		10.04
0167	0L1481	696617600						STEAM ELECTRIC VALVE; 24V-50HZ		276.10
0168	000000									
0169	0L2426	140600300						HOSE; BY METER; ØINT20X3 (ØEST=26)	From Ser. Nr.: 046 - Only for 165	13.30
0169	0L2426	140600300						HOSE; BY METER; ØINT20X3 (ØEST=26)	From Ser. Nr.: 046 - Only for 200	13.30
0169	0L2426	140600300						HOSE; BY METER; ØINT20X3 (ØEST=26)	From Ser. Nr.: 046 - Only for 300	13.30
0170	0L2423	5146A3B00						RUBBER HOLDER; MALE; G 1/2"	From Ser. Nr.: 046	24.66
0171	0L2424	5146A3C00						RUBBER HOLDER; FEMALE; G 1/2"	From Ser. Nr.: 046	24.66
0172	0L0918	541613400						CLUTCH	From Ser. Nr.: 046	8.77
0173	0L2425	5146A0100						THREAD QUICK CONNECTION	From Ser. Nr.: 046	20.40
0174	0L3456	5046A8U00			D			PUMP SUPPORT; FIR 5245- CAM1906	From Ser. Nr.: 3125	33.80



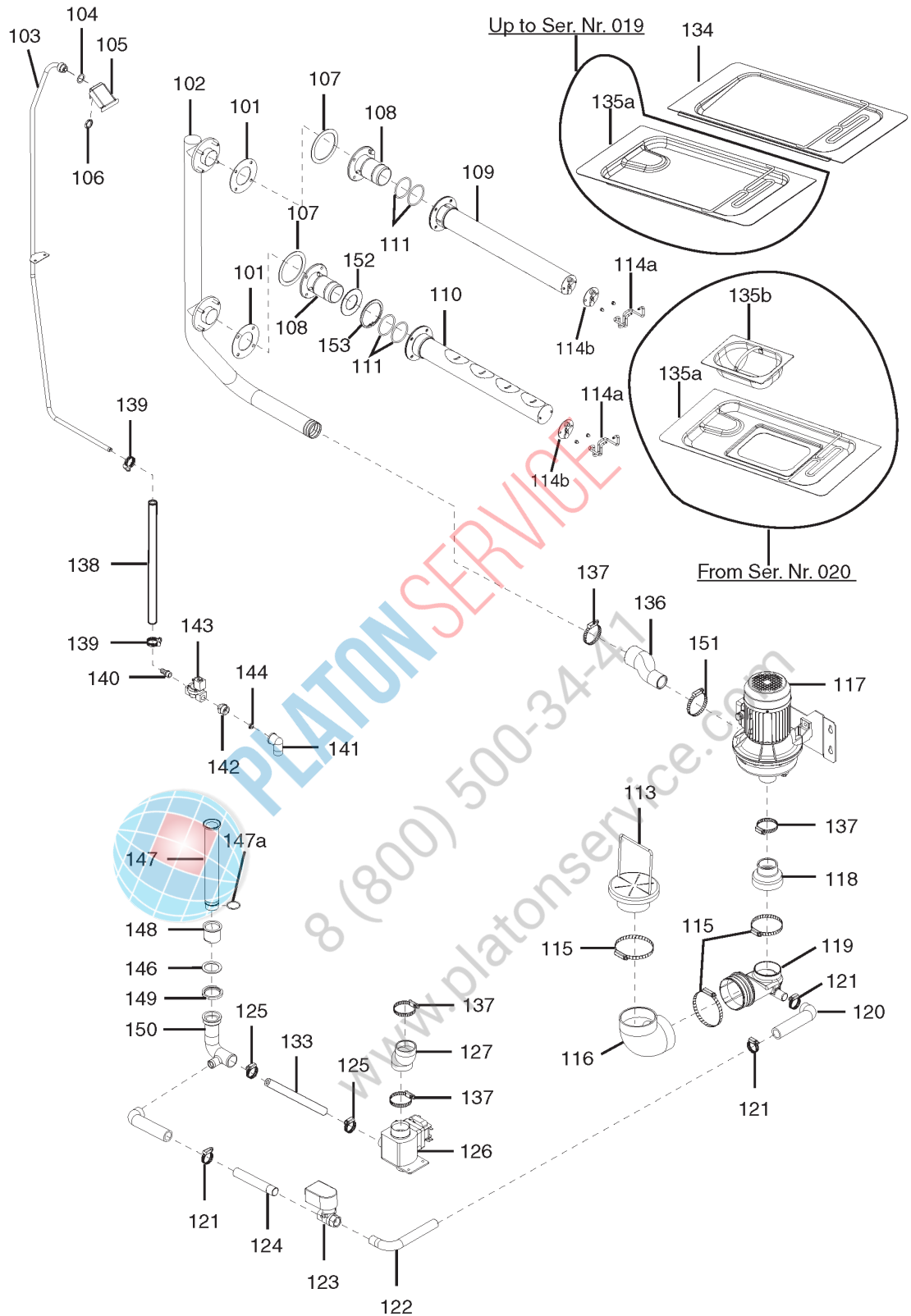

**iii. 652001p10A**

**Prelavaggio da 600, Circuito Idraulico/ Prewash from 600, Hydraulic circuit**

Da Ser.Nr./From Ser.nr.: 544

Page: 35 Ed. 2010-05

**Doc. Nr.: 6-52 001**

??????	534121								
??????	6-52001		???????? 35				Prewash from 600, Hydraulic circuit		
.		Alias		S			.		(Euro)
0101	0L0919	543629400		S			GASKET		4.65
0102	0L0958	830632701					WASH PIPE; LOWER	Up to Ser. Nr.: 616	271.00
0102	0L1186	830632703					TUBE; WASH M600 NEWRT	From Ser. Nr.: 617	187.80
0103	0L0981	830637801					FEEDER HOSE	Up to Ser. Nr.: 928	79.17
0103	0L1508	830649701					FEEDER HOSE; FOR TANK	From Ser. Nr.: 929	48.62
0104	0E5122	W00500800	0L2402				GASKET	Up to Ser.Nr.: 045	
0104	0L2402	569608800		S			GASKET; 29X21MM	From Ser.Nr.: 046	3.28
0105	0E5848	RT0011900					SPLASH GUARD		18.37
0106	0E5424	W00525400		S			NUT		4.73
0107	0L0923	543632400		S			O-RING		1.02
0108	0L0961	830633100	0L1188				SUPPORT; WASH PIPE	Up to Ser. Nr.: 616	
0108	0L1188	830633101					SUPPORT; FOR WASH TUBE	From Ser. Nr.: 617	139.10
0109	0L0974	830635702					WASH ARM	Up to Ser Nr: 5051	210.10
0109	0L3471	83065FS00					WASHING JET; UPPER; NEWRT	From Ser Nr: 5061	212.10
0110	0L0985	830641302					WASH ARM	Up to Ser Nr: 5051	211.10
0110	0L3472	83065FV00					WASHING JET; LOWER; NEWRT	From Ser Nr: 5061	212.10
0111	0L1276	543633200		S			O-RING; ØI=50X3 MM		1.47
0113	0L0951	800666601					PUMP STRAINER		104.50
0114	000000								
0115	0L0915	518682700					CLAMP; 100-120		5.29
0116	0L0930	544635700					SLEEVE		57.35
0117	0L0944	611630001		S			PUMP		780.00
0118	0L0933	544639600					MANIFOLD; SUCTION PUMP		25.78
0119	0L0927	544635100							
0120	049880	544631300		S			SLEEVE		13.30
0121	047578	518604001		S			CLAMP; 26-38		1.80
0122	0L0910	515660200					ELBOW HOSE		29.03
0123	0L0949	696616600		S			MOTORIZED SOLENOID VALVE; 24V 50/60HZ		154.30
0124	0L0911	515660300					TUBE		19.00
0125	0L0193	518614400		S			CLMAP; 40-60/9		2.01
0126	0L2506	696618600		S			DRAIN VALVE; 24V 50/60HZ		149.20
0127	0L0935	544640000					SLEEVE		20.60
0133	0L0939	544683100		S			RUBBER HOSE; L=70MM		11.41
0134	0L1167	830643401					TANK FILTER; TILTED M600 NEWRT		258.80
0136	0L0926	544635000					SLEEVE		32.07
0137	046855	518602801		S			HOSE CLAMP; 50-70/9		2.00

??????		534121									
??????		6-52001		???????? 35		Prewash from 600, Hydraulic circuit					
.		Alias		S			.			(Euro)	
0138	048531	140066039		S				RUBBER HOSE; ØI=12MM;ØE=19,5MM;BY METER	Up to Ser. Nr.: 045	9.55	
0138	049379	140066047		S				HOSE; WRC, 1PC=1130MM	From Ser. Nr.: 046	22.23	
0139	048126	518609801		S				CLIP; 13-20		1.58	
0140	0L0477	514694300						RUBBER HOLDER; USA		14.79	
0141	049679	544628400						ELBOW		19.98	
0142	0L0479	515655400		S				NIPPLE; USA		17.21	
0143	0L2516	696618500		S				SOLENOID VALVE; 3/8' 24V 50/60HZ		94.46	
0144	0L0178	549642800		S				PRESSURE REDUCER; 20L/MIN; ORANGE		4.22	
0146	065506	246037900		S				GASKET; ØI=42,86X3,53 MM		1.02	
0147	0L0909	515657900						OWERFLOW PIPE	Up to S. Nr. 712	52.17	
0147	0L1431	515657902	0L2296					OWERFLOW PIPE; NEWRT	From S. Nr. 713 - Up to S. Nr. 019		
0147	0L2296	830657400		S				OWERFLOW PIPE	From S. Nr. 020	11.82	
0148	075624	511607200		S	C			DRAIN		12.32	
0149	066079	215190400		S				RING NUT		24.66	
0150	0L0954	805659902						DRAIN MANIFOLD		69.83	
0151	046878	518602701		S				HOSE CLAMP; 35-50/9		1.91	
0152	0L1184	5026A3100						SHUTTER; M600 NEWRT	From Ser. Nr.: 617	6.76	
0153	0L1189	219065212		S				SNAP RING	From Ser. Nr.: 617	4.28	
135a	0L1166	830643300				CGX201 0-09		TANK FILTER; PREWASH M600 NEWRT	Up to Ser. Nr.: 019	235.50	
135a	0L2290	830656100						FILTER	From Ser. Nr.: 020	276.10	
135b	048252	830617602						FILTER	From Ser. Nr.: 020	62.83	

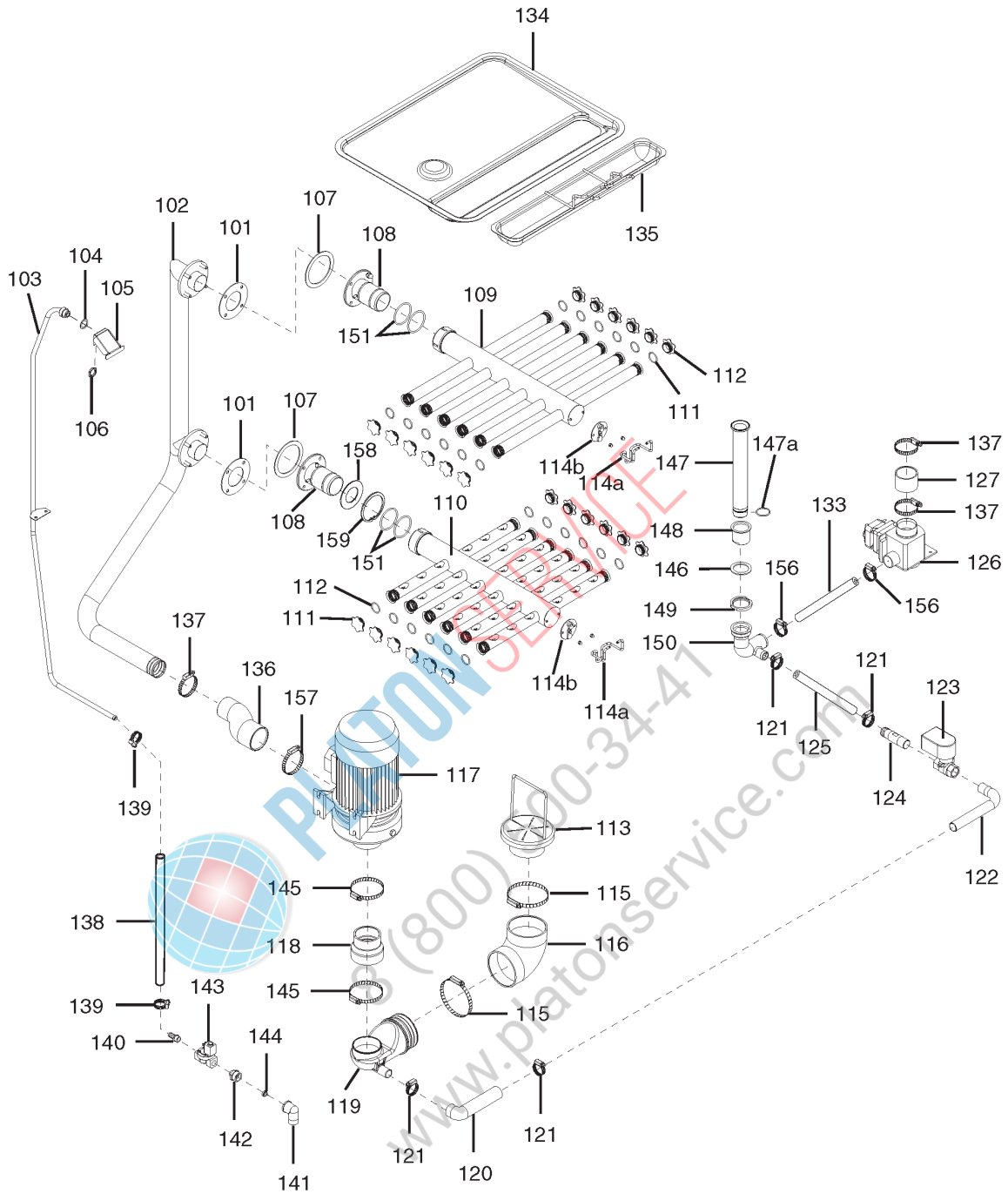

iii. 652001p11A

Prelavaggio da 1165, Circuito Idraulico/ Prewash from 1165, Hydraulic circuit

Da Ser.Nr./From Ser.nr.: 544

Page: 38 Ed. 2013-09

Doc. Nr.: 6-52 001

??????		534121									
??????		6-52001		???????? 38		Prewash from 1165, Hydraulic circuit					
.		Alias		S			.			(Euro)	
0101	0L0919	543629400		S				GASKET		4.65	
0102	0L0957	830632601						WASH PIPE; ASSY	Up to Ser. Nr.: 616	220.30	
0102	0L1187	830632603						TUBE; WASH M1165 NEWRT	From Ser. Nr.: 617	189.80	
0103	0L0981	830637801						FEEDER HOSE	Up to Ser. Nr.: 928	79.17	
0103	0L1508	830649701						FEEDER HOSE; FOR TANK	From Ser. Nr.: 929	48.62	
0104	0E5122	W00500800	0L2402					GASKET	Up to Ser.Nr.: 045		
0104	0L2402	569608800		S				GASKET; 29X21MM	From Ser.Nr.: 046	3.28	
0105	0E5848	RT0011900						SPLASH GUARD		18.37	
0106	0E5424	W00525400		S				NUT		4.73	
0107	0L0923	543632400		S				O-RING		1.02	
0108	0L0961	830633100	0L1188					SUPPORT; WASH PIPE	Up to Ser. Nr.: 616		
0108	0L1188	830633101						SUPPORT; FOR WASH TUBE	From Ser. Nr.: 617	139.10	
0109	0L0965	830633402						WASH ARM	Up to Ser. Nr.: 810 - Left machine	943.00	
0109	0L0965	830633502						WASH ARM	Up to Ser. Nr.: 810 - Right machine	943.00	
0109	0L1751	830654500	0L3475					WASH ARM	From Ser. Nr.: 811 - Left machine		
0109	0L1751	830654500	0L3475					WASH ARM	From Ser. Nr.: 811 - Right machine		
0109	0L1751	830654500	0L3475					WASH ARM	Up to Ser. Nr.: 5051 - Left machine		
0109	0L1751	830654500	0L3475					WASH ARM	Up to Ser. Nr.: 5051 - Right machine		
0109	0L3475	83065FY00						WASHING JET; UPPER	From Ser. Nr.: 5061 - Left machine	373.50	
0109	0L3475	83065FY00						WASHING JET; UPPER	From Ser. Nr.: 5061 - Right machine	373.50	
0110	0L0964	830633402						WASH ARM	Up to Ser. Nr.: 810 - Right machine	1,129.00	
0110	0L0964	830633502						WASH ARM	Up to Ser. Nr.: 810 - Left machine	1,129.00	
0110	0L1750	830654400	0L3476					WASH ARM	From Ser. Nr.: 811 - Right machine		
0110	0L1750	830654400	0L3476					WASH ARM	Up to Ser. Nr.: 5051 - Left machine		
0110	0L1750	830654400	0L3476					WASH ARM	Up to Ser. Nr.: 5051 - Right machine		
0110	0L1750	830654500	0L3476					WASH ARM	From Ser. Nr.: 811 - Left machine		
0110	0L3476	83065FZ00						WASHING JET; LOWER	From Ser. Nr.: 5061 - Left machine	373.50	
0110	0L3476	83065FZ00						WASHING JET; LOWER	From Ser. Nr.: 5061 - Right machine	373.50	
0111	0L0922	543632300		S				O-RING; ØI=26,65X2,62 MM		1.02	
0112	0L0978	830637000		S				PLUG; FOR WASH ARMS	Up to Ser. Nr.: 810	22.13	
0112	0L1711	541617400		S				PLUG; FOR WASH ARM	From Ser. Nr.: 811	1.68	
0113	0L0951	800666601						PUMP STRAINER		104.50	
0114	000000										
0115	0L0915	518682700						CLAMP; 100-120		5.29	
0116	0L0930	544635700						SLEEVE		57.35	

??????		534121									
??????		6-52001		???????? 38		Prewash from 1165, Hydraulic circuit					
.		Alias		S			.			(Euro)	
0117	0L0942	611629800	0L3036					PUMP; DWO 300; 230/400V 50HZ	Up to Ser. Nr.: 3241		
0117	0L3037	611637R00						PUMP; 5245-CAM 1906	From Ser. Nr.: 3251	769.00	
0118	0L0924	544629200	0L2545					SLEEVE	From Ser. Nr.: 3251		
0118	0L0932	544639500						SUCTION HOSE; SX; DWO300 NEWRT		7.43	
0118	0L0932	544639500						SUCTION HOSE; SX; DWO300 NEWRT	Up to Ser. Nr.: 3241	7.43	
0119	0L0928	544635200						SUCTION HOSE; SX		13.16	
0120	049880	544631300		S				SLEEVE		13.30	
0121	047578	518604001		S				CLAMP; 26-38		1.80	
0122	0L0910	515660200						ELBOW HOSE		29.03	
0123	0L0949	696616600		S				MOTORIZED SOLENOID VALVE; 24V 50/60HZ		154.30	
0124	0L0912	515660400						TUBE		40.40	
0125	049287	140066043		S				HOSE; ØE=30MM; ØI=25MM; L=430MM		10.39	
0126	0L2506	696618600		S				DRAIN VALVE; 24V 50/60HZ		149.20	
0127	0L0934	544639900		S				SLEEVE		5.61	
0133	0L0939	544683100		S				RUBBER HOSE; L=70MM		11.41	
0134	0L0892	504694300						FILTER		271.00	
0135	0L0973	830634900						FILTER BASKET; ASSY		169.50	
0136	0L0936	544640100						SLEEVE	Up to Ser. Nr.: 1324	39.08	
0136	0L1267	544683300						SLEEVE; ZF523V NEWRT	From Ser. Nr.: 1325	43.44	
0137	046855	518602801		S				HOSE CLAMP; 50-70/9		2.00	
0138	048531	140066039		S				RUBBER HOSE; ØI=12MM;ØE=19,5MM;BY METER	Up to Ser. Nr.: 045	9.55	
0138	049379	140066047		S				HOSE; WRC, 1PC=1130MM	From Ser. Nr.: 046	22.23	
0139	048126	518609801		S				CLIP; 13-20		1.58	
0140	0L0477	514694300						RUBBER HOLDER; USA		14.79	
0141	049679	544628400						ELBOW		19.98	
0142	0L0479	515655400		S				NIPPLE; USA		17.21	
0143	0L2516	696618500		S				SOLENOID VALVE; 3/8' 24V 50/60HZ		94.46	
0144	0L0178	549642800		S				PRESSURE REDUCER; 20L/MIN; ORANGE		4.22	
0145	0L0914	518682600		S				CLAMP		3.91	
0146	065506	246037900		S				GASKET; ØI=42,86X3,53 MM		1.02	
0147	0L0908	515657800		S				OWERFLOW PIPE	Up to Ser. Nr.: 712	58.57	
0147	0L1430	515657801	0L2295					OWERFLOW PIPE; NEWRT	From Ser. Nr.: 713 - Up to Ser. Nr.: 019		
0147	0L2295	830657300		S				OWERFLOW PIPE	From Ser. Nr.: 020	11.82	
0148	075624	511607200		S	C			DRAIN		12.32	
0149	066079	215190400		S				RING NUT		24.66	

??????	534121								
??????	6-52001		???????? 38				Prewash from 1165, Hydraulic circuit		
.		Alias		S			.		(Euro)
0150	0L0953	805659801		S			DRAIN MANIFOLD		90.03
0151	0L1276	543633200		S			O-RING; ØI=50X3 MM		1.47
0156	0L0193	518614400		S			CLMAP; 40-60/9		2.01
0157	046853	518602901		S			HOSE CLAMP; 60-80/9		2.53
0158	0L1185	5026A3000					SHUTTER; M1165 MODULARE NEWRT	From Ser. Nr.: 617	6.76
0159	0L1189	219065212		S			SNAP RING	From Ser. Nr.: 617	4.28



**PLATON SERVICE**

8 (800) 500-34-41

www.platonservice.com

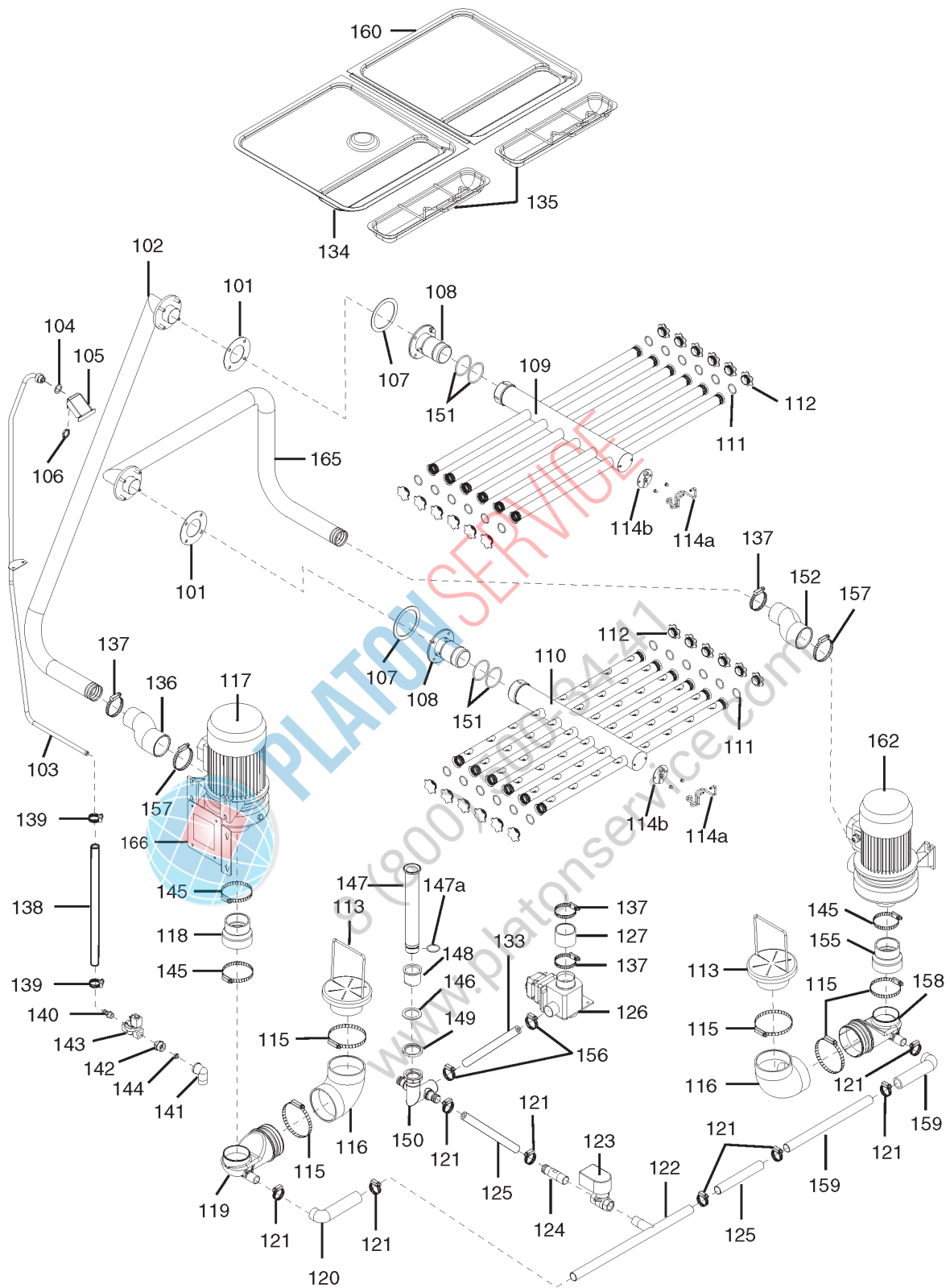

**iii. 652001p12**

**Prelavaggio da 1490, Circuito Idraulico/ Prewash from 1490, Hydraulic circuit**

Da Ser.Nr./From Ser.nr.: 544

Page: 41 Ed. 2015-06

**Doc. Nr.: 6-52 001**



??????	534121									
??????	6-52001		???????? 41					Prewash from 1490, Hydraulic circuit		
.		Alias		S			.			(Euro)
0015	000000									
0101	0L0919	543629400		S				GASKET		4.65
0102	0L0960	830632902						WASH ARM; UPPER		151.20
0103	0L0981	830637801						FEEDER HOSE	Up to Ser. Nr.: 928	79.17
0103	0L1508	830649701						FEEDER HOSE; FOR TANK	From Ser. Nr.: 929	48.62
0104	0E5122	W00500800	0L2402					GASKET	Up to Ser.Nr.: 045	
0104	0L2402	569608800		S				GASKET; 29X21MM	From Ser.Nr.: 046	3.28
0105	0E5848	RT0011900						SPLASH GUARD		18.37
0106	0E5424	W00525400		S				NUT		4.73
0107	0L0923	543632400		S				O-RING		1.02
0108	0L0961	830633100	0L1188					SUPPORT; WASH PIPE	Up to Ser. Nr.: 616	
0108	0L1188	830633101						SUPPORT; FOR WASH TUBE	From Ser. Nr.: 617	139.10
0109	0L0963	830633202			D			WASH ARM	Up to Ser. Nr.: 810 - Left machine	826.00
0109	0L0963	830633302			D			WASH ARM	Up to Ser. Nr.: 810 - Right machine	826.00
0109	0L1749	830654200						WASH ARM	From Ser. Nr.: 811 - Left machine	
0109	0L1749	830654300						WASH ARM	From Ser. Nr.: 811 - Right machine	
0109	0L1749	830654300						WASH ARM	Up to Ser. Nr.: 5051 - Left machine	
0109	0L1749	830654300						WASH ARM	Up to Ser. Nr.: 5051 - Right machine	
0109	0L3477	83065G000						WASHING JET; UPPER	From Ser. Nr.: 5061 - Left machine	403.00
0109	0L3477	83065G000						WASHING JET; UPPER	From Ser. Nr.: 5061 - Right machine	403.00
0110	0L0962	830633202			D			WASH ARM	Up to Ser. Nr.: 810 - Right machine	542.00
0110	0L0962	830633302			D			WASH ARM	Up to Ser. Nr.: 810 - Left machine	542.00
0110	0L1748	830654200	0L3478					WASH ARM	From Ser. Nr.: 811 - Right machine	
0110	0L1748	830654200	0L3478					WASH ARM	Up to Ser. Nr.: 5051 - Left machine	
0110	0L1748	830654200	0L3478					WASH ARM	Up to Ser. Nr.: 5051 - Right machine	
0110	0L1748	830654300	0L3478					WASH ARM	From Ser. Nr.: 811 - Left machine	
0110	0L3478	83065G100						WASHING JET; LOWER	From Ser. Nr.: 5061 - Left machine	392.80
0110	0L3478	83065G100						WASHING JET; LOWER	From Ser. Nr.: 5061 - Right machine	392.80
0111	0L0922	543632300		S				O-RING; ØI=26,65X2,62 MM		1.02
0112	0L0978	830637000		S				PLUG; FOR WASH ARMS	Up to Ser. Nr.: 810	22.13
0112	0L1711	541617400		S				PLUG; FOR WASH ARM	From Ser. Nr.: 811	1.68
0113	0L0951	800666601						PUMP STRAINER		104.50
0114	000000									
0115	0L0915	518682700						CLAMP; 100-120		5.29
0116	0L0930	544635700						SLEEVE		57.35

??????		534121									
??????		6-52001		???????? 41		Prewash from 1490, Hydraulic circuit					
.		Alias		S			.			(Euro)	
0117	0L0942	611629800	0L3036					PUMP; DWO 300; 230/400V 50HZ	Up to Ser. Nr.: 3241		
0117	0L3037	611637R00						PUMP; 5245-CAM 1906	From Ser. Nr.: 3251	769.00	
0118	0L0924	544629200	0L2545					SLEEVE	From Ser. Nr.: 3251		
0118	0L0932	544639500						SUCTION HOSE; SX; DWO300 NEWRT		7.43	
0118	0L0932	544639500						SUCTION HOSE; SX; DWO300 NEWRT	Up to Ser. Nr.: 3241	7.43	
0119	0L0928	544635200						SUCTION HOSE; SX		13.16	
0120	049880	544631300		S				SLEEVE		13.30	
0121	047578	518604001		S				CLAMP; 26-38		1.80	
0122	0L0913	515660600						TUBE		41.41	
0123	0L0949	696616600		S				MOTORIZED SOLENOID VALVE; 24V 50/60HZ		154.30	
0124	0L0912	515660400						TUBE		40.40	
0125	049287	140066043		S				HOSE; ØE=30MM; ØI=25MM; L=430MM		10.39	
0126	0L2506	696618600		S				DRAIN VALVE; 24V 50/60HZ		149.20	
0127	0L0934	544639900		S				SLEEVE		5.61	
0133	0L0939	544683100		S				RUBBER HOSE; L=70MM		11.41	
0134	0L0894	504694600						TANK FILTER		250.70	
0135	0L0972	830634802						FILTER BASKET; ASSY		155.30	
0136	0L0936	544640100						SLEEVE	Up to Ser. Nr.: 1324	39.08	
0136	0L1267	544683300						SLEEVE; ZF523V NEWRT	From Ser. Nr.: 1325	43.44	
0137	046855	518602801		S				HOSE CLAMP; 50-70/9		2.00	
0138	048531	140066039		S				RUBBER HOSE; ØI=12MM;ØE=19,5MM;BY METER	Up to Ser. Nr.: 045	9.55	
0138	049379	140066047		S				HOSE; WRC, 1PC=1130MM	From Ser. Nr.: 046	22.23	
0139	048126	518609801		S				CLIP; 13-20		1.58	
0140	0L0477	514694300						RUBBER HOLDER; USA		14.79	
0141	049679	544628400						ELBOW		19.98	
0142	0L0479	515655400		S				NIPPLE; USA		17.21	
0143	0L2516	696618500		S				SOLENOID VALVE; 3/8' 24V 50/60HZ		94.46	
0144	0L0178	549642800		S				PRESSURE REDUCER; 20L/MIN; ORANGE		4.22	
0145	0L0914	518682600		S				CLAMP		3.91	
0146	065506	246037900		S				GASKET; ØI=42,86X3,53 MM		1.02	
0147	0L0908	515657800		S				OWERFLOW PIPE	Up to S. Nr. 712	58.57	
0147	0L1430	515657801	0L2295					OWERFLOW PIPE; NEWRT	From S. Nr. 713 - Up to S. Nr. 019		
0147	0L2295	830657300		S				OWERFLOW PIPE	From Ser. Nr.: 020	11.82	
0148	075624	511607200		S	C			DRAIN		12.32	
0149	066079	215190400		S				RING NUT		24.66	

??????	534121								
??????	6-52001		???????? 41				Prewash from 1490, Hydraulic circuit		
.		Alias		S			.		(Euro)
0150	0L0953	805659801		S			DRAIN MANIFOLD		90.03
0151	0L1276	543633200		S			O-RING; ØI=50X3 MM		1.47
0152	0L0936	544640100					SLEEVE		39.08
0155	0L0924	544629200	0L2545				SLEEVE		
0156	0L0193	518614400		S			CLMAP; 40-60/9		2.01
0157	046853	518602901		S			HOSE CLAMP; 60-80/9		2.53
0159	0L0912	515660400					TUBE		40.40
0160	0L0893	504694500					TANK FILTER		250.70
0162	0L0943	611629902		S			PUMP		621.00
0165	0L0959	830632802					WASH PIPE; LOWER		151.20
0166	0L3456	5046A8U00			D		PUMP SUPPORT; FIR 5245-CAM1906	From Ser. Nr.: 3125	33.80



**PLATON SERVICE**  
 8 (800) 500-34-41  
[www.platonservice.com](http://www.platonservice.com)

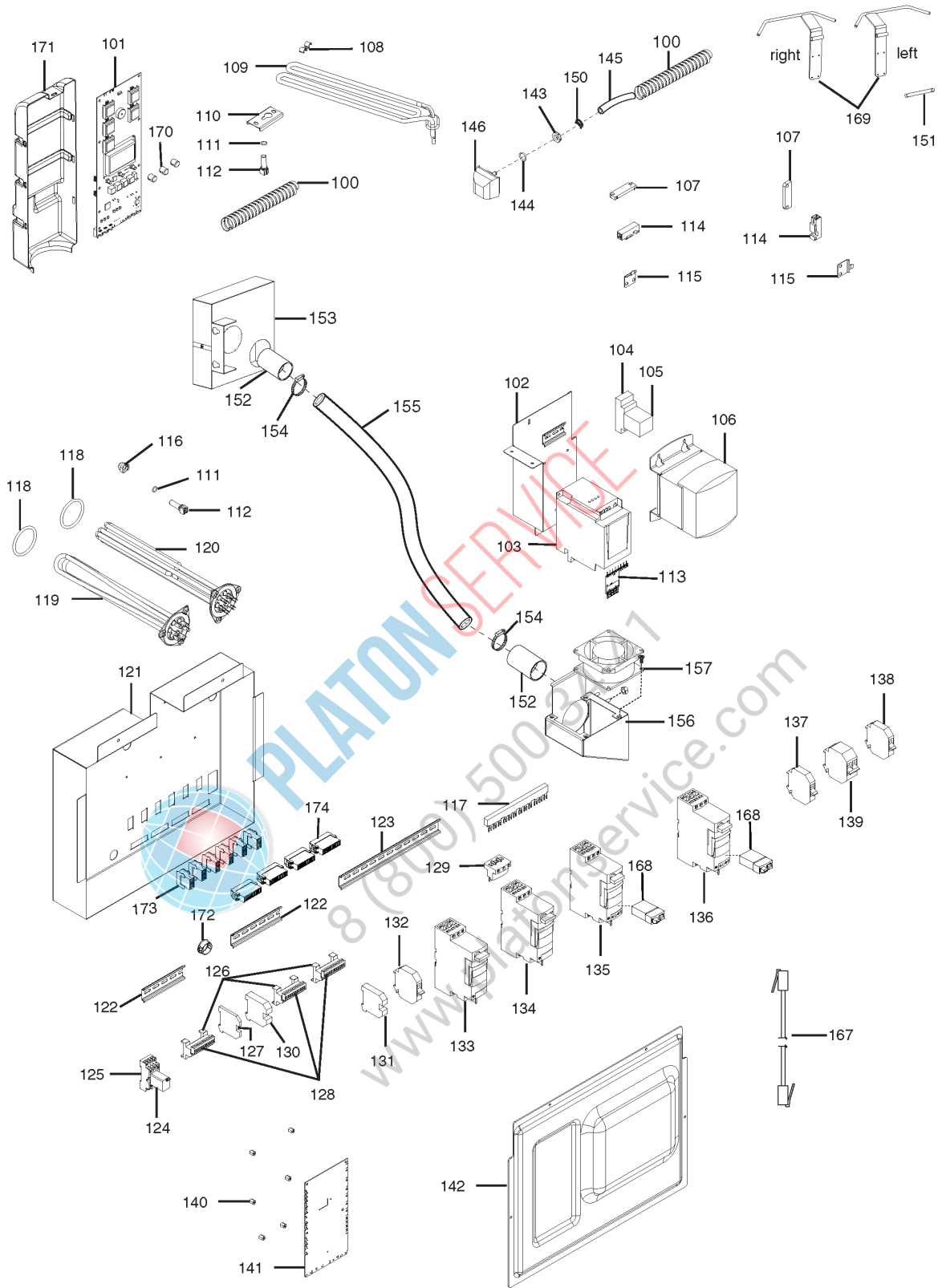

**ill. 652001p13**

**Risciacquo da 600, Componenti elettrici/ Rinse from 600, Electrical components**

Da Ser.Nr./From Ser.nr.: 544

Page: 45 Ed. 2011-12

**Doc. Nr.: 6-52 001**

??????		534121											
??????		6-52001		???????? 45		Rinse from 600, Electrical components							
.		Alias		S			.						(Euro)
0100	0L1948	W00050701	0L1949							SHEATH			
0101	0L0998	673607500						D		PCB; USER INTERFACE	Up to Ser. Nr.: 628		495.30
0101	0L0998	673607501						D		PCB; USER INTERFACE	From Ser. Nr.: 629 - Up to Ser. Nr.: 639		495.30
0101	0L1285	673610006						S		USER INTERFACE BOARD; HV NEW RT	From Ser. Nr.: 640		413.10
0101	0L1285	673610006						S		USER INTERFACE BOARD; HV NEW RT	Up to Ser. Nr.: 4501		413.10
0101	0L3462	673612B00								USER INTERFACE BOARD	From Ser. Nr.: 4511		450.70
0102	0L1253	830640204								SUPPORT; FOR TRANSFORMER	Up to Ser. Nr.: 146		43.85
0102	0L2579	830640205								SUPPORT; FOR TRANSFORMER	From Ser. Nr.: 147		44.56
0103	0L1000	624605000	0L1282							AUTOMATIC CIRCUIT BREAKER; 370W-200/240V	Up to Ser. Nr.: 639		
0103	0L1282	624605700	0L1913							INVERTER; ATV11 200/240V 50/60HZ	From Ser. Nr.: 640 - Up to Ser. Nr.: 835		
0103	0L1913	624606100						D	CGX201 1-04	INVERTER; ATV11 0.55KW 200/240V 50/60	From Ser. Nr.: 836 - Up to Ser. Nr.: 146		319.70
0103	0L2511	830658900						S	+	INVERTER ATV12; 0,55KW 200/240V 50/60HZ	From Ser. Nr.: 147 - Up to Ser. Nr.: 4501		351.20
0103	0L3457	83065DV00								INVERTER; ATV12	From Ser. Nr.: 4511		356.30
0104	0E5171	W00501700								TERMINAL BOARD			18.05
0105	0E5170	W00501800						S		RELAY; 24V 3 CONTACT			34.65
0106	0L1158	624605600						S		TRANSFORMER; 230V/24V 400VA			198.90
0107	0L2534	699605900						S		MAGNET; 63X18X7MM			24.16
0108	048429	506675402						S		BRACKET			2.01
0109	0L1002	617623300						S		HEATING ELEMENT; 3000W 400V			58.67
0110	0L0366	507683800						S		SUPPORT			3.44
0111	0L2303	543633Z00						S		O-RING; DIA.9,25X1,78			1.02
0112	049643	124294000						S		TEMPERATURE PROBE			9.76
0113	0L2510	673611S00						S		PCB	From Ser. Nr.: 147		80.69
0113	0L2510	673611S00						S		PCB	Up to Ser. Nr.: 4501		80.69
0114	049621	654600000						S	C	+	REED SWITCH		15.00
0115	0L3164	502698502								SENSOR SUPPORT			9.93
0116	0L0280	514693100						S		STUFFING BOX			11.51
0117	0L1004	639626900								CONNECTION BAR			34.41
0118	0L2304	543633Y00						S		O-RING; DIA.56.52X5.33			4.54
0119	0L1005	617623100						S		HEATING ELEMENT; 6000W 230V			79.17
0120	0L1006	617623000						S		HEATING ELEMENT; 6000W 230V	WTM140		80.19
0120	0L1035	617623200	0L2242							HEATING ELEMENT; 10500W 230V	Up to Ser. Nr.: 040 - Not for WTM140		
0120	0L2759	617632101						S		HEATING ELEMENT; 230V-10500W; RIGHT	From Ser. Nr.: 041 - Not for WTM140		96.02
0121	0L1007	502694501	0L2090							EL. COMPONENTS BOX	Up to Ser. Nr.: 928		
0121	0L2090	850663N01								EL. COMPONENTS BOX	From Ser. Nr.: 929		138.00
0122	0E3032	W00010100	0E3045					D		RUNNER			

??????	534121									
??????	6-52001		???????? 45				Rinse from 600, Electrical components			
.		Alias		S			.			(Euro)
0123	0L1008	506608100	0TH191				SUPPORT			
0124	0L1009	648614400					RELAY			27.00
0125	0L0415	648613700		S			RELAY BASE			14.01
0126	0L1010	639627000		S			CONNECTOR			25.58
0127	0L1609	639627700					TERMINAL; GREEN/YELLOW			13.20
0128	0L1012	639627100					CONNECTOR; MSTB 2,5/12-ST			18.78
0129	0L1013	639626600					TERMINAL BOARD; GV1-G09 63A	Up to Ser Nr: 4501		24.46
0130	0L1054	W00508900					TERMINAL; YELLOW/GREEN TERMINAL BLOCK			17.71
0131	0E5850	W00508400	0F0112				CONNECTION; NEUTRAL			
0132	0E6015	652606000					SWITCH			25.78
0133	0L1016	648614301		S			SWITCH; MOTOR START-UP UNIT	8A÷32A		138.00
0134	0L1017	648614201					SWITCH; MOTOR START-UP UNIT	3A÷12A		138.00
0135	0L1018	648614101	0L1222				SWITCH; MOTOR START-UP UNIT	1.25A÷5A Up to Ser. Nr.: 620		
0135	0L1222	648614102		S			SWITCH; MOTOR START-UP UNIT	1.25A÷5A From Ser. Nr.: 621		158.30
0136	0L1018	648614101	0L1222				SWITCH; MOTOR START-UP UNIT	1.25A÷5A Up to Ser. Nr.: 620		
0136	0L1222	648614102		S			SWITCH; MOTOR START-UP UNIT	1.25A÷5A From Ser. Nr.: 621 Up to Ser. Nr.: 706		158.30
0136	0L1297	648613901		S			AUTOMATIC CIRCUIT BREAKER	0.35A÷1.4A From Ser. Nr.: 707		158.30
0137	0L1019	652607100					AUTOMATIC CIRCUIT BREAKER			35.63
0138	0L1021	652607300					AUTOMATIC CIRCUIT BREAKER			29.94
0139	0L1020	652607400					AUTOMATIC CIRCUIT BREAKER; TYPE GB2 DB1			57.96
0140	088653	516807900					SPACER			2.23
0141	0L1022	673607702	0L1246				PCB	Up to Ser. Nr.: 628		
0141	0L1246	673609500			D	CGX200 6-23	PCB; NEW RT	From Ser. Nr.: 629 - Up to Ser. Nr.: 639		313.60
0141	0L1284	673610103		S			PCB; MEC12R; 180-254V; 50/60HZ	From Ser. Nr.: 640		360.30
0141	0L1284	673610103		S			PCB; MEC12R; 180-254V; 50/60HZ	Up to Ser. Nr.: 4501		360.30
0141	0L3465	673612D00					PCB; MEC12R;W/OUT BOX	From Ser. Nr.: 4511		361.30
0142	0L1023	541613700					COVERING			59.89
0143	049268	544623800		S			HEX NUT; M14X1,5			1.80
0144	068642	246035800		S			O-RING; ØI=15,54X2,62			1.02
0145	072393	W00537200		S			HOSE; Ø=4X7,4MM; L=500CM; PRESSURE SWITC			11.67
0146	048308	542604901		S			AIR TRAP; FOR PRESSURE GAUGE			4.44
0150	0L0082	518613000		S			CLAMP; DIA. 7,3-7,8MM			1.02
0151	0L1449	514699000					AXIS; NEWRT			5.60
0152	0L2552	544687900					SLEEVE	From Ser. Nr.: 147		15.31
0153	0L2558	800674400					AIR GUIDE	From Ser. Nr.: 147		27.20

??????		534121									
??????		6-52001		???????? 45		Rinse from 600, Electrical components					
.		Alias		S			.			(Euro)	
0154	0L0193	518614400		S				CLMAP; 40-60/9	From Ser. Nr.: 147	2.01	
0155	000000	140600601							From Ser. Nr.: 4511		
0155	0L2505	140600400						HOSE; BY METER	From Ser. Nr.: 147	42.43	
0155	0L2505	140600400						HOSE; BY METER	Up to Ser. Nr.: 4501	42.43	
0156	0L2559	830658700						AIR GUIDE	From Ser. Nr.: 147	41.92	
0157	0L2175	549646500						FAN; 80X80X38 208/240V 50/60HZ	From Ser. Nr.: 147	121.80	
0167	0L1396	639629000	0L2212					CABLE; RJ11 3600MM	Up to Ser. Nr: 019		
0167	0L1432	639629200		S				TELEPHONE CABLE; L=6000 MM	From Ser. Nr.: 020	22.74	
0167	0L1432	639629200		S				TELEPHONE CABLE; L=6000 MM	Up to Ser. Nr.: 4501	22.74	
0167	0L3458	63868CG00						COMMUNICATION CABLE; L=6000MM	From Ser. Nr.: 4511	27.61	
0168	0L1441	648615200		S				CONTACT; LUFC00 S204		42.93	
0169	0L1164	830645801						LEVER; START DX	From Ser. Nr.: 718 - Right machines	52.68	
0169	0L1165	830645901						LEVER; START SX	From Ser. Nr.: 718 - Left machines	52.68	
0170	002670	548836902		S				EXTENSION; L=6,95MM		1.02	
0171	0L1484	541615500						PROTECTION BOX; HV NEWRT		37.96	
0172	0L2325	543613800						BUSHING; DIA.17,5MM	From Ser. Nr.: 020	1.02	
0173	0L2386	699605700						MALE CONNECTOR; 4 VIE	From Ser. Nr.: 037	1.58	
0174	0L2387	699605800						MALE CONNECTOR; 8 VIE	From Ser. Nr.: 037	2.12	

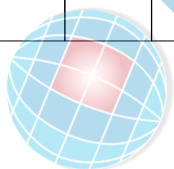

8 (800) 500-3441  
www.platonservice.com





??????	534121									
??????	6-52001		???????? 49				Wash from 1165, Electrical components			
.		Alias		S			.			(Euro)
0100	0L1948	W00050701	0L1949				SHEATH			
0101	048308	542604901		S			AIR TRAP; FOR PRESSURE GAUGE			4.44
0102	068642	246035800		S			O-RING; ØI=15,54X2,62			1.02
0103	049268	544623800		S			HEX NUT; M14X1,5			1.80
0104	072393	W00537200		S			HOSE; Ø=4X7,4MM; L=500CM; PRESSURE SWITC			11.67
0105	049621	654600000		S	C	+	REED SWITCH			15.00
0106	0L3164	502698502					SENSOR SUPPORT			9.93
0107	0L2534	699605900		S			MAGNET; 63X18X7MM			24.16
0108	0L1024	830635201					LEVER; AUTOSTART	Up to Ser. Nr.: 616		39.69
0108	0L1164	830645801					LEVER; START DX	Right machines From Ser. Nr.: 617		52.68
0108	0L1165	830645901					LEVER; START SX	Left machines From Ser. Nr.: 617		52.68
0110	0L0366	507683800		S			SUPPORT			3.44
0111	0L2303	543633Z00		S			O-RING; DIA.9,25X1,78			1.02
0112	049643	124294000		S			TEMPERATURE PROBE			9.76
0115	0L0082	518613000		S			CLAMP; DIA. 7,3-7,8MM			1.02
0116	0L1005	617623100		S			HEATING ELEMENT; 6000W 230V			79.17
0117	0L1006	617623000		S			HEATING ELEMENT; 6000W 230V			80.19
0118	0L2304	543633Y00		S			O-RING; DIA.56.52X5.33			4.54
0120	0L1025	639626700					CONNECTION BAR	for 2 start controller		21.01
0121	0L1026	502693203		S			ELECTRIC PANEL			247.70
0123	0L1226	639626800					CONNECTION BAR	for 3 start controller		28.01
0124	0L1013	639626600					TERMINAL BOARD; GV1-G09 63A			24.46
0125	0L0415	648613700		S			RELAY BASE			14.01
0126	0L1010	639627000		S			CONNECTOR			25.58
0127	0L1027	507621700					BAR; DIN; L 265			1.02
0128	0L1012	639627100					CONNECTOR; MSTB 2,5/12-ST			18.78
0129	0L1609	639627700					TERMINAL; GREEN/YELLOW			13.20
0130	0L1009	648614400					RELAY			27.00
0131	0E6015	652606000					SWITCH			25.78
0132	0L1028	639627300					MAIN TERMINAL BOARD			23.95
0133	0L1016	648614301		S			SWITCH; MOTOR START-UP UNIT	8A÷32A		138.00
0135	0L1036	648615300		S			ASSY; LUB12 + LUCA12B + LUA1 C11	3A÷12A		175.60
0137	0L1297	648613901		S			AUTOMATIC CIRCUIT BREAKER	0.35A÷1.4A		158.30
0139	0L1033	506606900	0TH191				CONNECTION BAR			
0140	088653	516807900					SPACER			2.23

??????		534121									
??????		6-52001		???????? 49		Wash from 1165, Electrical components					
.		Alias		S			.				(Euro)
0141	0L1022	673607702	0L1246					PCB	Up to Ser. Nr.: 628 - You cannot have old and new electronic boards both installed in the same machine		
0141	0L1246	673609500			D	CGX200 6-23		PCB; NEW RT	From Ser. Nr.: 629 - Up to Ser. Nr.: 639 - You cannot have old and new electronic boards both installed in the same machine	313.60	
0141	0L1284	673610103		S				PCB; MEC12R; 180-254V; 50/60HZ	From Ser. Nr.: 640 - You cannot have old and new electronic boards both installed in the same machine	360.30	
0141	0L1284	673610103		S				PCB; MEC12R; 180-254V; 50/60HZ	Up to Ser. Nr.: 4501 - You cannot have old and new electronic boards both installed in the same machine	360.30	
0141	0L3465	673612D00						PCB; MEC12R; W/OUT BOX	From Ser. Nr.: 4511 - You cannot have old and new electronic boards both installed in the same machine	361.30	
0142	0L1034	541613800						COVERING		77.85	
0143	0L0698	640612700			D	CGX200 9-02		KNOB		29.94	
0144	0L0363	640612500			D	CGX200 9-02		MAIN SWITCH; 4-P 125A	Up to Ser. Nr.: 019	138.00	
0144	0L2066	640613300		S				MAIN SWITCH; WITH KNOB	From Ser. Nr.: 020	140.10	
0145	0E3032	W00010100	0E3045		D			RUNNER			
0146	0L1011	639627600						TERMINAL BOARD; GREEN/ YELLOW		21.52	
0147	0L2447	639629S00						TERMINAL END PIECE		9.29	
0151	0L1449	514699000						AXIS; NEWRT		5.60	
0167	0L1396	639629000	0L2212					CABLE; RJ11 3600MM	Up to Ser. Nr.: 019		
0167	0L1432	639629200		S				TELEPHONE CABLE; L=6000 MM	From Ser. Nr.: 020	22.74	
0167	0L1432	639629200		S				TELEPHONE CABLE; L=6000 MM	Up to Ser. Nr.: 4501	22.74	
0167	0L3458	63868CG00						COMMUNICATION CABLE; L=6000MM	From Ser. Nr.: 4511	27.61	
0168	0L1441	648615200		S				CONTACT; LUFC00 S204		42.93	
0169	0L2325	543613800						BUSHING; DIA.17,5MM	From Ser. Nr.: 020	1.02	
0173	0L2386	699605700						MALE CONNECTOR; 4 VIE	From Ser. Nr.: 037	1.58	
0174	0L2387	699605800						MALE CONNECTOR; 8 VIE	From Ser. Nr.: 037	2.12	

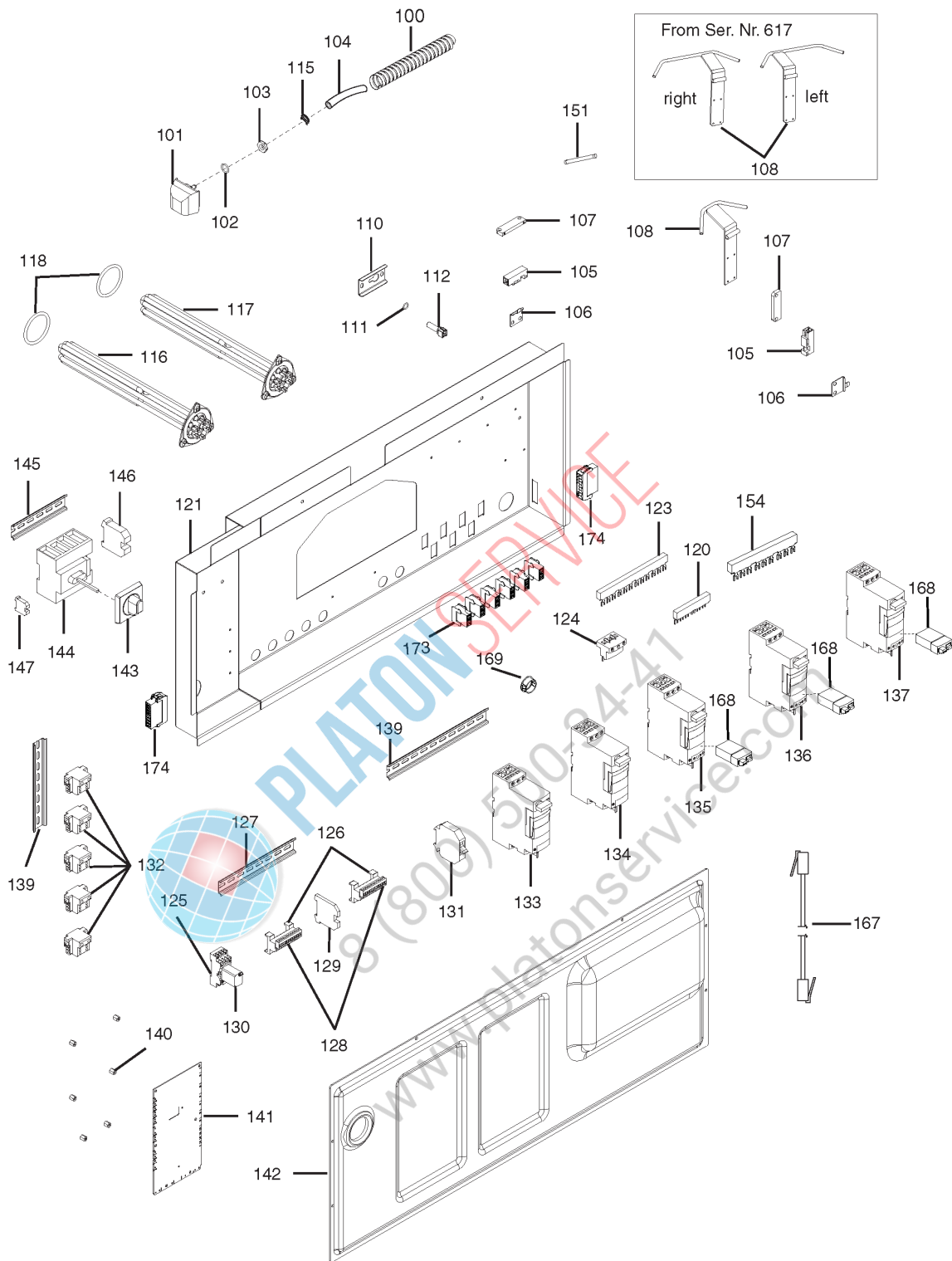

**iii. 652001p15A**

**Lavaggio da 1490, Componenti elettrici/ Wash from 1490, Electrical components**

Da Ser.Nr./From Ser.nr.: 544

Page: 52 Ed. 2010-09

**Doc. Nr.: 6-52 001**

??????	534121									
??????	6-52001		???????? 52				Wash from 1490, Electrical components			
.		Alias		S			.			(Euro)
0100	0L1948	W00050701	0L1949				SHEATH			
0101	048308	542604901		S			AIR TRAP; FOR PRESSURE GAUGE			4.44
0102	068642	246035800		S			O-RING; ØI=15,54X2,62			1.02
0103	049268	544623800		S			HEX NUT; M14X1,5			1.80
0104	072393	W00537200		S			HOSE; Ø=4X7,4MM; L=500CM; PRESSURE SWITC			11.67
0105	049621	654600000		S	C	+	REED SWITCH			15.00
0106	0L3164	502698502					SENSOR SUPPORT			9.93
0107	0L2534	699605900		S			MAGNET; 63X18X7MM			24.16
0108	0L1024	830635201					LEVER; AUTOSTART	Up to Ser. Nr.: 616		39.69
0108	0L1164	830645801					LEVER; START DX	From Ser. Nr.: 617 - Right machines		52.68
0108	0L1165	830645901					LEVER; START SX	From Ser. Nr.: 617 - Left machines		52.68
0110	0L0366	507683800		S			SUPPORT			3.44
0111	0L2303	543633Z00		S			O-RING; DIA.9,25X1,78			1.02
0112	049643	124294000		S			TEMPERATURE PROBE			9.76
0115	0L0082	518613000		S			CLAMP; DIA. 7,3-7,8MM			1.02
0116	0L1039	617623500	0L2243				HEATING ELEMENT; 10500W	Up to Ser. Nr.: 040 - 230 V		
0116	0L2736	617632201		S			HEATING ELEMENT; 230V 10500W; LEFT	From Ser. Nr.: 041 - 230 V		91.25
0117	0L1035	617623200	0L2242				HEATING ELEMENT; 10500W 230V	Up to Ser. Nr.: 040 - 230 V		
0117	0L2759	617632101		S			HEATING ELEMENT; 230V-10500W; RIGHT	From Ser. Nr.: 041 - 230 V		96.02
0118	0L2304	543633Y00		S			O-RING; DIA.56.52X5.33			4.54
0120	0L1025	639626700					CONNECTION BAR	for 2 start controller		21.01
0121	0L1026	502693201		S			ELECTRIC PANEL			247.70
0123	0L1004	639626900					CONNECTION BAR	for 4 start controller		34.41
0124	0L1013	639626600					TERMINAL BOARD; GV1-G09 63A			24.46
0125	0L0415	648613700		S			RELAY BASE			14.01
0126	0L1010	639627000		S			CONNECTOR			25.58
0127	0L1027	507621700					BAR; DIN; L 265			1.02
0128	0L1012	639627100					CONNECTOR; MSTB 2,5/12-ST			18.78
0129	0L1609	639627700					TERMINAL; GREEN/YELLOW			13.20
0130	0L1009	648614400					RELAY			27.00
0131	0E6015	652606000					SWITCH			25.78
0132	0L1028	639627300					MAIN TERMINAL BOARD			23.95
0133	0L1016	648614301		S			SWITCH; MOTOR START-UP UNIT	8A÷32A only for WTM140 WTM250 WTM300		138.00
0133	0L1029	648614001					SWITCH; MOTOR START-UP UNIT	4.5A÷18A only for WTM165 WTM200		138.00
0134	0L1016	648614301		S			SWITCH; MOTOR START-UP UNIT	8A÷32A only for WTM250 WTM300		138.00

??????		534121											
??????		6-52001		???????? 52		Wash from 1490, Electrical components							
.		Alias		S			.					(Euro)	
0134	0L1029	648614001							SWITCH; MOTOR START-UP UNIT	4.5A;-18A only for WTM165 WTM200		138.00	
0135	0L1036	648615300		S					ASSY; LUB12 + LUCA12B + LUA1 C11			175.60	
0136	0L1018	648614101	0L1222						SWITCH; MOTOR START-UP UNIT	Up to S.N.620			
0136	0L1222	648614102		S					SWITCH; MOTOR START-UP UNIT	From S.N.621		158.30	
0137	0L1297	648613901		S					AUTOMATIC CIRCUIT BREAKER			158.30	
0139	0L1033	506606900	0TH191						CONNECTION BAR				
0140	088653	516807900							SPACER			2.23	
0141	0L1022	673607702	0L1246						PCB	Up to S.N.628 - You cannot have old and new electronic boards both installed in the same machine			
0141	0L1246	673609500			D	CGX200 6-23			PCB; NEW RT	From S.N.629 - You cannot have old and new electronic boards both installed in the same machine		313.60	
0141	0L1246	673609500			D	CGX200 6-23			PCB; NEW RT	Up S.N.639 - You cannot have old and new electronic boards both installed in the same machine		313.60	
0141	0L1284	673610102		S					PCB; MEC12R; 180-254V; 50/60HZ	From S.N.640 - You cannot have old and new electronic boards both installed in the same machine		360.30	
0141	0L1284	673610102		S					PCB; MEC12R; 180-254V; 50/60HZ	Up S.N.4501 - You cannot have old and new electronic boards both installed in the same machine		360.30	
0141	0L3465	673612D00							PCB; MEC12R;W/OUT BOX	From S.N.4511 - You cannot have old and new electronic boards both installed in the same machine		361.30	
0142	0L1034	541613800							COVERING			77.85	
0143	0L0968	640612700							SUPPORT; RINSE LOWER	Up S.N.0201		73.99	
0143	0L2067	640613400		S					KNOB	From S.N.0201		28.93	
0144	0L0363	640612500			D	CGX200 9-02			MAIN SWITCH; 4-P 125A	Up S.N.0201		138.00	
0144	0L2066	640613300		S					MAIN SWITCH; WITH KNOB	From S.N.0201		140.10	
0145	0E3032	W00010100	0E3045		D				RUNNER				
0146	0L1011	639627600							TERMINAL BOARD; GREEN/YELLOW			21.52	
0147	0L2447	639629S00							TERMINAL END PIECE			9.29	
0151	0L1449	514699000							AXIS; NEWRT			5.60	
0154	0L1226	639626800							CONNECTION BAR	for 3 start controller		28.01	
0167	0L1396	639629000	0L2212						CABLE; RJ11 3600MM	Up to Ser. Nr.: 019			
0167	0L1432	639629200		S					TELEPHONE CABLE; L=6000 MM	From Ser. Nr.:020		22.74	
0167	0L1432	639629200		S					TELEPHONE CABLE; L=6000 MM	Up to Ser. Nr.: 4501		22.74	
0167	0L3458	63868CG00							COMMUNICATION CABLE; L=6000MM	From Ser. Nr.: 4511		27.61	
0168	0L1441	648615200		S					CONTACT; LUFC00 S204			42.93	
0169	0L2325	543613800							BUSHING; DIA.17,5MM	From Ser. Nr.: 020		1.02	
0173	0L2386	699605700							MALE CONNECTOR; 4 VIE	From Ser. Nr.: 037		1.58	

??????	534121								
??????	6-52001	???????? 52	Wash from 1490, Electrical components						
.		Alias		S		.			(Euro)
0174	0L2387	699605800					MALE CONNECTOR; 8 VIE	From Ser. Nr.: 037	2.12



**PLATON SERVICE**

8 (800) 500-34-41

[www.platonservice.com](http://www.platonservice.com)

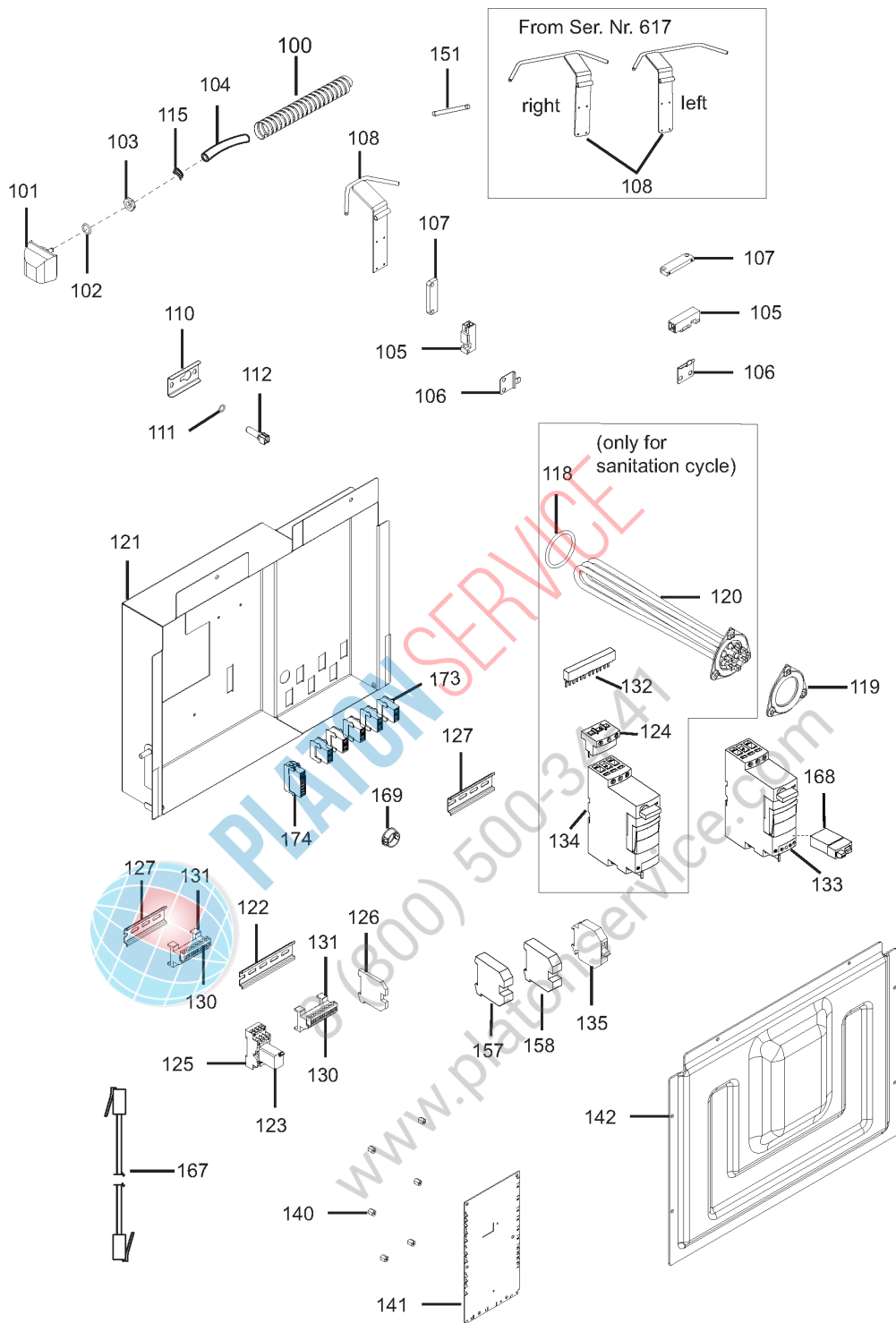

**iii. 652001p16A**

**Prelavaggio da 600, Componenti elettrici / Prewash from 600, Electrical components**

Da Ser.Nr./From Ser.nr.: 544

Page: 55 Ed. 2008-09

**Doc. Nr.: 6-52 001**

??????	534121										
??????	6-52001		???????? 55							Prewash from 600, Electrical components	
.		Alias		S			.				(Euro)
0100	0L1948	W00050701	0L1949							SHEATH	
0101	048308	542604901		S						AIR TRAP; FOR PRESSURE GAUGE	4.44
0102	068642	246035800		S						O-RING; ØI=15,54X2,62	1.02
0103	049268	544623800		S						HEX NUT; M14X1,5	1.80
0104	072393	W00537200		S						HOSE; Ø=4X7,4MM; L=500CM; PRESSURE SWITC	11.67
0105	049621	654600000		S	C	+				REED SWITCH	15.00
0106	0L3164	502698502								SENSOR SUPPORT	9.93
0107	0L2534	699605900		S						MAGNET; 63X18X7MM	24.16
0108	0L1024	830635201								LEVER; AUTOSTART	Up to Ser. Nr.: 616 39.69
0108	0L1164	830645801								LEVER; START DX	From Ser. Nr.: 617 - Right machines 52.68
0108	0L1165	830645901								LEVER; START SX	From Ser. Nr.: 617 - Left machines 52.68
0110	0L0366	507683800		S						SUPPORT	3.44
0111	0L2303	543633Z00		S						O-RING; DIA.9,25X1,78	1.02
0112	049643	124294000		S						TEMPERATURE PROBE	9.76
0115	0L0082	518613000		S						CLAMP; DIA. 7,3-7,8MM	1.02
0118	0L2304	543633Y00		S						O-RING; DIA.56.52X5.33	Only for sanitization cycle 4.54
0119	049928	507682600		S						FLANGE	Up to Ser. Nr.: 146 13.52
0119	0L2629	511620B00		S						FLANGE	From Ser. Nr.: 147 12.46
0120	0L1035	617623200	0L2242							HEATING ELEMENT; 10500W 230V	From Ser. Nr.: 617 - Left machines
0120	0L2759	617632101		S						HEATING ELEMENT; 230V-10500W; RIGHT	Up to Ser. Nr.: 040 - Only for sanitization cycle 96.02
0121	0L1610	502693401								PANEL; PREWASH NEWRT	From Ser. Nr.: 041 - Only for sanitization cycle 167.50
0122	0E3032	W00010100	0E3045		D					RUNNER	
0123	0L1009	648614400								RELAY	27.00
0124	0L1013	639626600								TERMINAL BOARD; GV1-G09 63A	Only for sanitization cycle 24.46
0125	0L0415	648613700		S						RELAY BASE	14.01
0126	0L1609	639627700								TERMINAL; GREEN/YELLOW	13.20
0127	0L1037	507689200								CONNECTION BAR; L. 100MM	1.76
0130	0L1012	639627100								CONNECTOR; MSTB 2,5/12-ST	18.78
0131	0L1010	639627000		S						CONNECTOR	25.58
0132	0L1025	639626700								CONNECTION BAR	Only for sanitization cycle 21.01
0133	0L1222	648614102		S						SWITCH; MOTOR START-UP UNIT	1.25A÷5A 158.30
0134	0L1016	648614301		S						SWITCH; MOTOR START-UP UNIT	8A÷32A - Only for sanitization cycle 138.00
0135	0E6015	652606000								SWITCH	25.78
0140	088653	516807900								SPACER	2.23
0141	0L1022	673607702	0L1246							PCB	Up to Ser. Nr.: 628 - You cannot have old and new electronic boards both installed in the same machine



??????		534121									
??????		6-52001		???????? 55		Prewash from 600, Electrical components					
.		Alias		S			.			(Euro)	
0141	0L1246	673609500			D		CGX200 6-23	PCB; NEW RT	From Ser. Nr.: 629 - Up to Ser. Nr.: 639 - You cannot have old and new electronic boards both installed in the same machine	313.60	
0141	0L1284	673610103		S				PCB; MEC12R; 180-254V; 50/60HZ	From Ser. Nr.: 640 - You cannot have old and new electronic boards both installed in the same machine	360.30	
0141	0L1284	673610103		S				PCB; MEC12R; 180-254V; 50/60HZ	Up to Ser. Nr.: 4501 - You cannot have old and new electronic boards both installed in the same machine	360.30	
0141	0L3465	673612D00						PCB; MEC12R;W/OUT BOX	From Ser. Nr.: 4511 - You cannot have old and new electronic boards both installed in the same machine	361.30	
0142	0L1038	541613600						COVERING		60.60	
0151	0L1449	514699000						AXIS; NEWRT		5.60	
0157	0L1054	W00508900						TERMINAL; YELLOW/GREEN TERMINAL BLOCK		17.71	
0158	0E5850	W00508400	0F0112					CONNECTION; NEUTRAL			
0167	0L1396	639629000	0L2212					CABLE; RJ11 3600MM	Up to Ser. Nr.: 019		
0167	0L1432	639629200		S				TELEPHONE CABLE; L=6000 MM	From Ser. Nr.: 020	22.74	
0167	0L1432	639629200		S				TELEPHONE CABLE; L=6000 MM	Up to Ser. Nr.: 4501	22.74	
0167	0L3458	63868CG00						COMMUNICATION CABLE; L=6000MM	From Ser. Nr.: 4511	27.61	
0168	0L1441	648615200		S				CONTACT; LUFC00 S204		42.93	
0169	0L2325	543613800						BUSHING; DIA.17,5MM	From Ser. Nr.: 020	1.02	
0173	0L2386	699605700						MALE CONNECTOR; 4 VIE	From Ser. Nr.: 037	1.58	
0174	0L2387	699605800						MALE CONNECTOR; 8 VIE	From Ser. Nr.: 037	2.12	

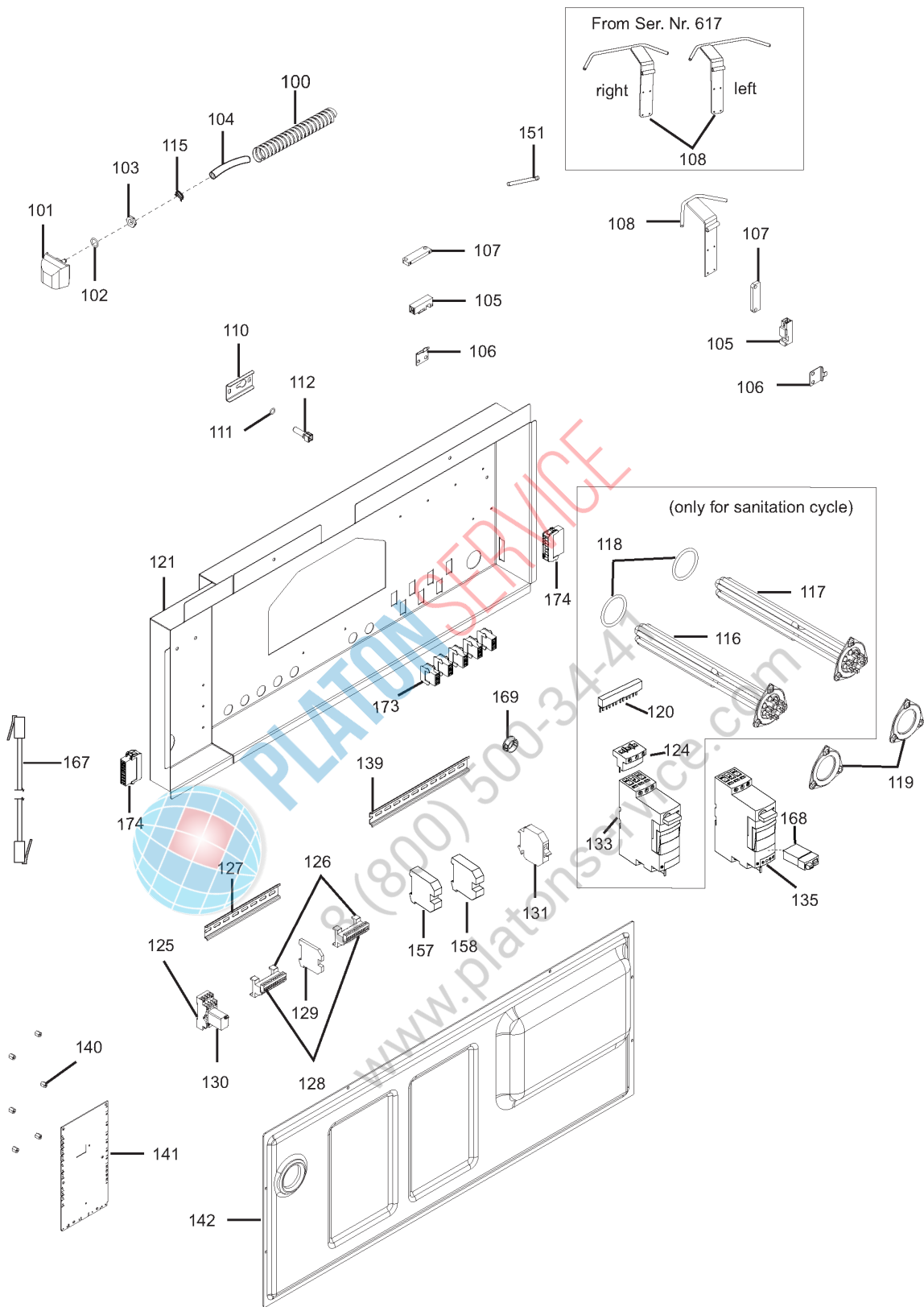

**iii. 652001p17A**

**Prelavaggio da 1165, Componenti elettrici / Prewash from 1165, Electrical components**

Da Ser.Nr./From Ser.nr.: 544

Page: 58 Ed. 2010-09

**Doc. Nr.: 6-52 001**

??????	534121										
??????	6-52001		???????? 58							Prewash from 1165, Electrical components	
.		Alias		S			.				(Euro)
0100	0L1948	W00050701	0L1949							SHEATH	
0101	048308	542604901		S						AIR TRAP; FOR PRESSURE GAUGE	4.44
0102	068642	246035800		S						O-RING; ØI=15,54X2,62	1.02
0103	049268	544623800		S						HEX NUT; M14X1,5	1.80
0104	072393	W00537200		S						HOSE; Ø=4X7,4MM; L=500CM; PRESSURE SWITC	11.67
0105	049621	654600000		S	C	+				REED SWITCH	15.00
0106	0L3164	502698502								SENSOR SUPPORT	9.93
0107	0L2534	699605900		S						MAGNET; 63X18X7MM	24.16
0108	0L1024	830635201								LEVER; AUTOSTART	Up to Ser. Nr.: 616 39.69
0108	0L1164	830645801								LEVER; START DX	From Ser. Nr.: 617 - Right machines 52.68
0108	0L1165	830645901								LEVER; START SX	From Ser. Nr.: 617 - Left machines 52.68
0110	0L0366	507683800		S						SUPPORT	3.44
0111	0L2303	543633Z00		S						O-RING; DIA.9,25X1,78	1.02
0112	049643	124294000		S						TEMPERATURE PROBE	9.76
0115	0L0082	518613000		S						CLAMP; DIA. 7,3-7,8MM	1.02
0116	0L1039	617623500	0L2243							HEATING ELEMENT; 10500W	Up to Ser. Nr.: 040 - Only for sanitization cycle
0116	0L2736	617632201		S						HEATING ELEMENT; 230V 10500W; LEFT	From Ser. Nr.: 041 - Only for sanitization cycle 91.25
0117	0L1006	617623000		S						HEATING ELEMENT; 6000W 230V	Only for sanitization cycle 80.19
0118	0L2304	543633Y00		S						O-RING; DIA.56.52X5.33	Only for sanitization cycle 4.54
0119	049928	507682600		S						FLANGE	Up to Ser. Nr.: 146 13.52
0119	0L2629	511620B00		S						FLANGE	From Ser. Nr.: 147 12.46
0120	0L1025	639626700								CONNECTION BAR	Only for sanitization cycle 21.01
0121	0L1026	502693201		S						ELECTRIC PANEL	247.70
0124	0L1013	639626600								TERMINAL BOARD; GV1-G09 63A	Only for sanitization cycle 24.46
0125	0L0415	648613700		S						RELAY BASE	14.01
0126	0L1010	639627000		S						CONNECTOR	25.58
0127	0L1027	507621700								BAR; DIN; L 265	1.02
0128	0L1012	639627100								CONNECTOR; MSTB 2,5/12-ST	18.78
0129	0L1609	639627700								TERMINAL; GREEN/YELLOW	13.20
0130	0L1009	648614400								RELAY	27.00
0131	0E6015	652606000								SWITCH	25.78
0133	0L1016	648614301		S						SWITCH; MOTOR START-UP UNIT	8A÷32A - Only for sanitization cycle 138.00
0135	0L1036	648615300		S						ASSY; LUB12 + LUCA12B + LUA1 C11	3A÷12A 175.60
0139	0L1033	506606900	0TH191							CONNECTION BAR	
0140	088653	516807900								SPACER	2.23

??????	534121									
??????	6-52001		???????? 58				Prewash from 1165, Electrical components			
.		Alias		S			.			(Euro)
0141	0L1022	673607702	0L1246				PCB	Up to Ser. Nr.: 628 - You cannot have old and new electronic boards both installed in the same machine		
0141	0L1246	673609500			D	CGX200 6-23	PCB; NEW RT	From Ser. Nr.: 629 - Up to Ser. Nr.: 639 - You cannot have old and new electronic boards both installed in the same machine	313.60	
0141	0L1284	673610103		S			PCB; MEC12R; 180-254V; 50/60HZ	From Ser. Nr.: 640 - You cannot have old and new electronic boards both installed in the same machine	360.30	
0141	0L1284	673610103		S			PCB; MEC12R; 180-254V; 50/60HZ	Up to Ser. Nr.: 4501 - You cannot have old and new electronic boards both installed in the same machine	360.30	
0141	0L3465	673612D00					PCB; MEC12R; W/OUT BOX	From Ser. Nr.: 4511 - You cannot have old and new electronic boards both installed in the same machine	361.30	
0142	0L1034	541613800					COVERING		77.85	
0151	0L1449	514699000					AXIS; NEWRT		5.60	
0157	0L1054	W00508900					TERMINAL; YELLOW/GREEN TERMINAL BLOCK		17.71	
0158	0E5850	W00508400	0F0112				CONNECTION; NEUTRAL			
0167	0L1432	639629200		S			TELEPHONE CABLE; L=6000 MM	Up to Ser Nr: 4501	22.74	
0167	0L3458	63868CG00					COMMUNICATION CABLE; L=6000MM	From Ser Nr: 4511	27.61	
0168	0L1441	648615200		S			CONTACT; LUFC00 S204		42.93	
0169	0L2325	543613800					BUSHING; DIA.17,5MM	From Ser. Nr.: 020	1.02	
0173	0L2386	699605700					MALE CONNECTOR; 4 VIE	From Ser. Nr.: 037	1.58	
0174	0L2387	699605800					MALE CONNECTOR; 8 VIE	From Ser. Nr.: 037	2.12	

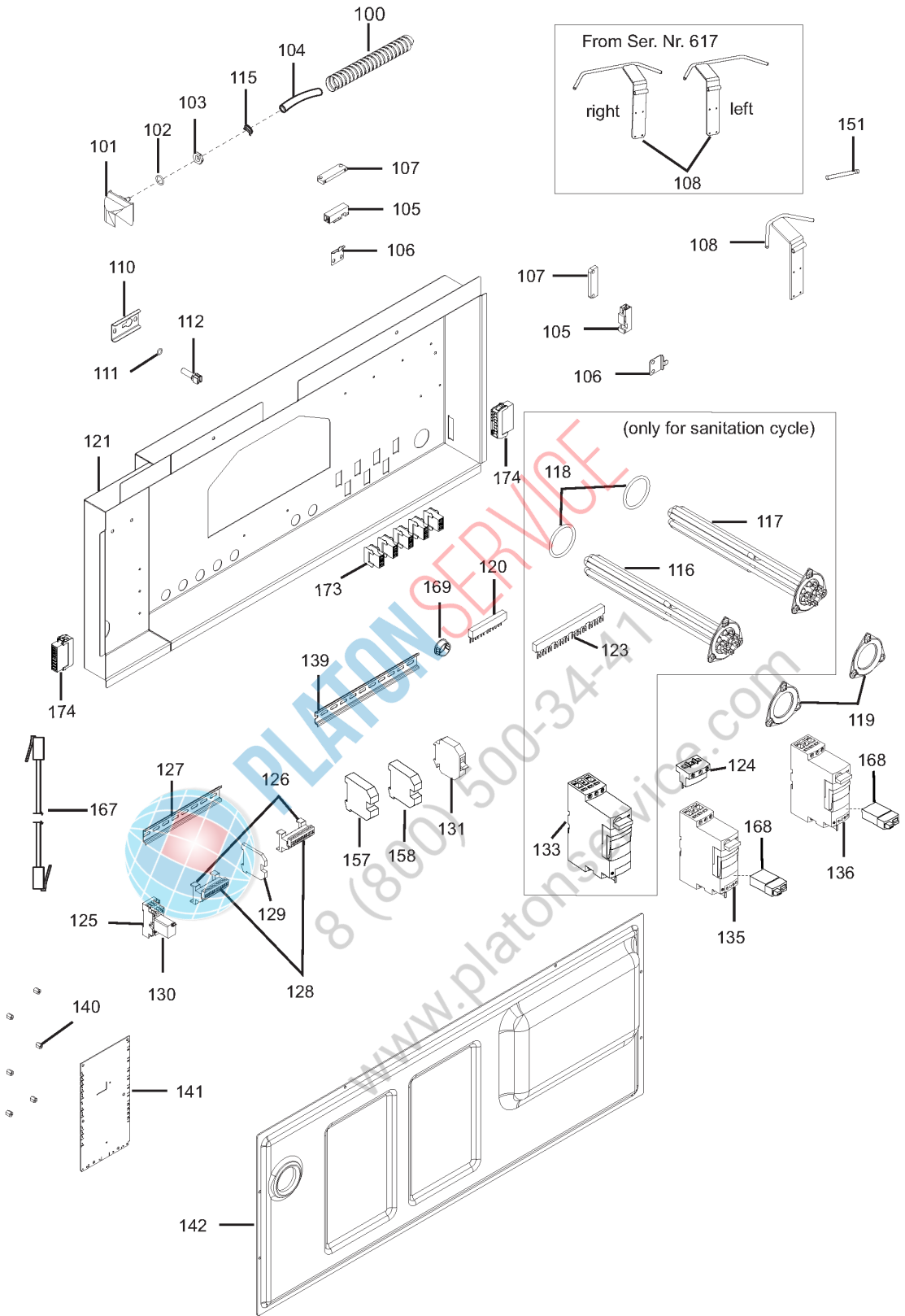

**ill. 652001p18A**

**Prelavaggio da 1490, Componenti elettrici / Prewash from 1490, Electrical components**

Da Ser.Nr./From Ser.nr.: 544	<b>Doc. Nr.: 6-52 001</b>
Page: <b>61</b> Ed. 2010-09	

??????		534121											
??????		6-52001		???????? 61		Prewash from 1490, Electrical components							
.		Alias		S			.						(Euro)
0100	0L1948	W00050701	0L1949							SHEATH			
0101	048308	542604901		S						AIR TRAP; FOR PRESSURE GAUGE			4.44
0102	068642	246035800		S						O-RING; ØI=15,54X2,62			1.02
0103	049268	544623800		S						HEX NUT; M14X1,5			1.80
0104	072393	W00537200		S						HOSE; Ø=4X7,4MM; L=500CM; PRESSURE SWITC			11.67
0105	049621	654600000		S	C	+				REED SWITCH			15.00
0106	0L3164	502698502								SENSOR SUPPORT			9.93
0107	0L2534	699605900		S						MAGNET; 63X18X7MM			24.16
0108	0L1024	830635201								LEVER; AUTOSTART	Up to Ser. Nr.: 616		39.69
0108	0L1164	830645801								LEVER; START DX	From Ser. Nr.: 617 - Right machines		52.68
0108	0L1165	830645901								LEVER; START SX	From Ser. Nr.: 617 - Left machines		52.68
0110	0L0366	507683800		S						SUPPORT			3.44
0111	0L2303	543633Z00		S						O-RING; DIA.9,25X1,78			1.02
0112	049643	124294000		S						TEMPERATURE PROBE			9.76
0115	000000												
0116	0L1039	617623500	0L2243							HEATING ELEMENT; 10500W	Up to Ser. Nr.: 040 - Only for sanitization cycle		
0116	0L2736	617632201		S						HEATING ELEMENT; 230V 10500W; LEFT	From Ser. Nr.: 041 - Only for sanitization cycle		91.25
0117	0L1006	617623000		S						HEATING ELEMENT; 6000W 230V	Only for sanitization cycle		80.19
0118	0L2304	543633Y00		S						O-RING; DIA.56.52X5.33	Only for sanitization cycle		4.54
0119	049928	507682600		S						FLANGE	Up to Ser. Nr.: 146		13.52
0119	0L2629	511620B00		S						FLANGE	From Ser. Nr.: 147		12.46
0120	0L1025	639626700								CONNECTION BAR	for 2 start controller		21.01
0121	0L1026	502693201		S						ELECTRIC PANEL			247.70
0123	0L1004	639626900								CONNECTION BAR	Only for sanitization cycle		34.41
0124	0L1013	639626600								TERMINAL BOARD; GV1-G09 63A			24.46
0125	0L0415	648613700		S						RELAY BASE			14.01
0126	0L1010	639627000		S						CONNECTOR			25.58
0127	0L1027	507621700								BAR; DIN; L 265			1.02
0128	0L1012	639627100								CONNECTOR; MSTB 2,5/12-ST			18.78
0129	0L1609	639627700								TERMINAL; GREEN/YELLOW			13.20
0130	0L1009	648614400								RELAY			27.00
0131	0E6015	652606000								SWITCH			25.78
0133	0L1016	648614301		S						SWITCH; MOTOR START-UP UNIT	8A÷32A - Only for sanitization cycle		138.00
0135	0L1036	648615300		S						ASSY; LUB12 + LUCA12B + LUA1 C11	3A÷12A		175.60
0136	0L1018	648614101	0L1222							SWITCH; MOTOR START-UP UNIT	Up to Ser. Nr.: 620 - 1.25A÷5A		
0136	0L1222	648614102		S						SWITCH; MOTOR START-UP UNIT	1.25A÷5A From Ser. Nr.: 621		158.30

??????		534121									
??????		6-52001		???????? 61		Prewash from 1490, Electrical components					
.		Alias		S		.				(Euro)	
0139	0L1033	506606900	0TH191					CONNECTION BAR			
0140	088653	516807900						SPACER		2.23	
0141	0L1022	673607702	0L1246					PCB	Up to Ser. Nr.: 628 - You cannot have old and new electronic boards both installed in the same machine		
0141	0L1246	673609500			D	CGX200 6-23		PCB; NEW RT	From Ser. Nr.: 629 - Up to Ser. Nr.: 639 - You cannot have old and new electronic boards both installed in the same machine	313.60	
0141	0L1284	673610103		S				PCB; MEC12R; 180-254V; 50/60HZ	From Ser. Nr.: 640 - You cannot have old and new electronic boards both installed in the same machine	360.30	
0141	0L1284	673610103		S				PCB; MEC12R; 180-254V; 50/60HZ	Up to Ser. Nr.: 4501 - You cannot have old and new electronic boards both installed in the same machine	360.30	
0141	0L3465	673612D00						PCB; MEC12R;W/OUT BOX	From Ser. Nr.: 4511 - You cannot have old and new electronic boards both installed in the same machine	361.30	
0142	0L1034	541613800						COVERING		77.85	
0151	0L1449	514699000						AXIS; NEWRT		5.60	
0157	0L1054	W00508900						TERMINAL; YELLOW/GREEN TERMINAL BLOCK		17.71	
0158	0E5850	W00508400	0F0112					CONNECTION; NEUTRAL			
0167	0L1432	639629200		S				TELEPHONE CABLE; L=6000 MM	Up to Ser. Nr.: 4501	22.74	
0167	0L3458	63868CG00						COMMUNICATION CABLE; L=6000MM	From Ser. Nr.: 4511	27.61	
0168	0L1441	648615200		S				CONTACT; LUFC00 S204		42.93	
0169	0L2325	543613800						BUSHING; DIA.17,5MM	From Ser. Nr.: 020	1.02	
0173	0L2386	699605700						MALE CONNECTOR; 4 VIE	From Ser. Nr.: 037	1.58	
0174	0L2387	699605800						MALE CONNECTOR; 8 VIE	From Ser. Nr.: 037	2.12	